

VDR22 Design Series Variable Volume Vane Pump

30 ℓ /min 14MPa
40 ℓ /min 7MPa

Features

① Stable, highly efficient operation up to 14MPa

A biased piston that minimizes ring vibration and leak-free pressure balance construction enables highly efficient high-pressure operation, and very stable performance up to 14MPa.

② High-precision instantaneous response

Response has been improved by a special bias piston mechanism. Prompt response at both ON-OFF and OFF-ON

ensures instantaneous, stable, high-precision operation.

③ Silent operation, even in the high pressure range

Quiet journal bearings, a bias piston that allows a 3-point support system, and new suction and discharge port shapes all contribute to minimize operation noise. Silent, vibration-free operation is ensured, even in the high pressure range.

④ Reduced power loss

A combination of NACHI-original mechanical innovations and precision machining create a pump that minimizes power loss, especially at full cutoff.

⑤ Solid construction stands up to harsh operating conditions

The tough and rugged construction of this pump is made possible by a long history of quality pump designs. This, in combination with specially selected materials and skilled workmanship, provides outstanding durability.

Specifications

Single Pump

Model No.	Capacity cm ³ /rev	No-load Discharge Rate (ℓ /min)				Pressure Adjustment Range MPa(kgf/cm ²)	Allowable Peak Pressure MPa(kgf/cm ²)	Revolution Speedmin ⁻¹		Weight kg
		1000min ⁻¹	1200min ⁻¹	1500min ⁻¹	1800min ⁻¹			Min.	Max.	
VDR-1A(B)-1A2-22 1A3 1A4 1A5	16.7	16.7	20	25	30	1.5 to 3.5 {15.3 to 35.7}	14 {143}	800	1800	9
3 to 7 {30.6 to 71.4}										
6.5 to 10.5 {66.3 to 107}										
9 to 14 {91.8 to 143}										
VDR-1A(B)-2A2-22 2A3	22	22	27	33	40	1.5 to 3.5 {15.3 to 35.7}	14 {143}	800	1800	9
3 to 7 {30.6 to 71.4}										

Double Pump

Model No.	Vent Side		Shaft Side		Vent Side	Shaft Side	Revolution Speedmin ⁻¹		Weight kg
	Discharge Rate ℓ /min	Pressure Adjustment Range MPa(kgf/cm ²)	Discharge Rate ℓ /min	Pressure Adjustment Range MPa(kgf/cm ²)			Allowable Peak Pressure MPa(kgf/cm ²)	Min.	
VDR-11A(B)-1A2-1A2-22 VDR-11A(B)-1A2-1A3-22	30	1.5 to 3.5 {15.3 to 35.7}	30	1.5 to 3.5{15.3 to 35.7}	14 {143}	800	1800	17	
VDR-11A(B)-1A3-1A3-22		3 to 7 {30.6 to 71.4}		3 to 7 {30.6 to 71.4}					
VDR-11A(B)-2A2-2A2-22 VDR-11A(B)-2A2-2A3-22	40	1.5 to 3.5 {15.3 to 35.7}	40	1.5 to 3.5{15.3 to 35.7}	14 {143}	800	1800	17	
VDR-11A(B)-2A3-2A3-22		3 to 7 {30.6 to 71.4}		3 to 7 {30.6 to 71.4}					

Note) 1. The discharge rate is the value at 1800min⁻¹ no-load.

2. The change from design number 21 to design number 22 represents a change in the shaft key width from 3.2mm to 4.76mm. This means that when using a 3.2mm key coupling, you need to use a stepped key (VD31J-302000) or add a new key groove at 4.76.

● Handling

① Rotation Direction

The direction of rotation is always clockwise (rightward) when viewed from the shaft side.

② Drain

Drain piping must be direct piping up to a point that is below the tank fluid level, and back pressure due to pipe resistance should not exceed 0.03MPa. When using a pump that has drain ports at two locations, use the drain port that is higher after the pump is installed.

③ Discharge Volume Adjustment

The discharge flow rate is decreased by clockwise (rightward) rotation of the discharge rate adjusting screw, and increased by counterclockwise (leftward) rotation. Loosen the lock nut before making adjustments. After adjustment is complete, re-tighten the lock nut. The graph on the right provides general guidelines for the relationship between the rotation angle of the flow rate adjusting screw and the no-load discharge rate.

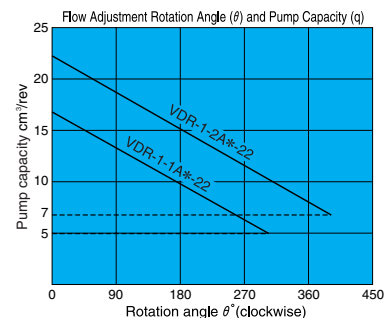

(Continued on following page)

However: $Q=q \times n \times 10^{-3}$

Q :No-load Discharge Rate Q ℓ/min

q :Volume cm³/rev

N :Revolution Speed min⁻¹

The broken line shows the flow volume adjustment range lower limit value.

Note)

The values indicated above are at maximum discharge volume with the flow volume adjusting screw at the 0° position.

4 Pressure Adjustment

Pressure is decreased by clockwise (rightward) rotation of the discharge rate adjusting screw, and

increased by counterclockwise (leftward) rotation.

5 Factory Default P-Q Settings (Standard Model)

- Flow Rate Setting = Maximum flow rate for model as indicated in the catalog

- Pressure Setting = Pressure shown in table to the right

6 Thrust Screw

The thrust screw is precision adjusted at the factory during assembly. Never touch the thrust screw. See callout **2** in the cross-section diagram on page B-11.

Factory Default Pressure Settings MPa{kgf/cm ² }	
2	: 3.5 {35.7}
3	: 3 {30.6}
4	: 6.5 {66.3}
5	: 9 {91.8}

7 Initial Operation

Before operating the pump for the first time, put the pump discharge side into the no-load state and then repeatedly start and stop the motor to bleed all air from inside the pump and the suction piping. After confirming that the pump is discharging oil, continue the no-load operation for at least 10 minutes to discharge all the air from the circuit.

Provide an air bleed valve in circuits where it is difficult to bleed air before startup.

8 Sub Plate

Use the following table for specification when a sub plate is required.

For detailed dimensions, see pages B-17 through B-19.

9 For the hydraulic operating fluid,

Pump Model No.	Sub Plate Number	Motor(kW)
VDR-1A-1A*-22	MVD-1-115-10	0.75 to 1.5
	MVD-1-135-10	2.2 to 3.7
VDR-1A-2A*-22	MVD-1-115Y-10	0.75 to 1.5
	MVD-1-135Y-10	2.2 to 3.7
VDR-11A-*A* -*A*-22	MVD-11-135-10	1.5 to 3.7
	MVD-11-135X-10	

use type ISO VG32 or equivalent (viscosity index of at least 90) for pressures of 7MPa or lower, and type ISO VG68 or equivalent (viscosity index of at least 90) for pressures greater than 7MP.

10The operating temperature range is 15 to 60°C. When the oil temperature at startup is 15°C or less, perform a warm-up operation at low pressure until the oil temperature reaches 15°C. Use the pump in an area where the temperature is within the range of 0 to 60°C.

11Suction pressure is -0.03 to +0.03MPa (-0.3 to +0.3kgf/cm²), and the suction port flow rate should be to greater than 2m/sec.

12Avoid pulley, gear, and other drive systems that impart a radial or thrust load on the end of the pump shaft. Mount the pump so its pump shaft is oriented horizontally.

(Continued on following page)

Understanding Model Numbers

Single pump

VDR-1 A-1 A 2-22

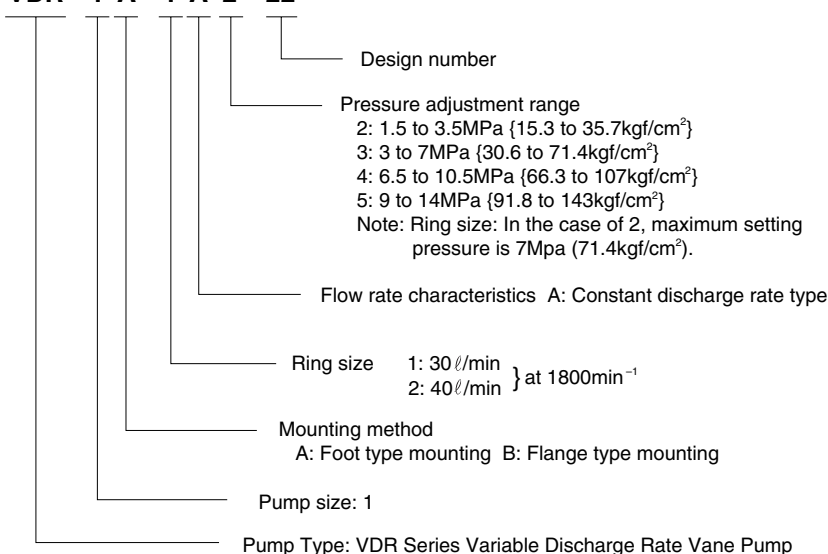

Double pump

VDR-11 A-1 A 2-1 A 3-22

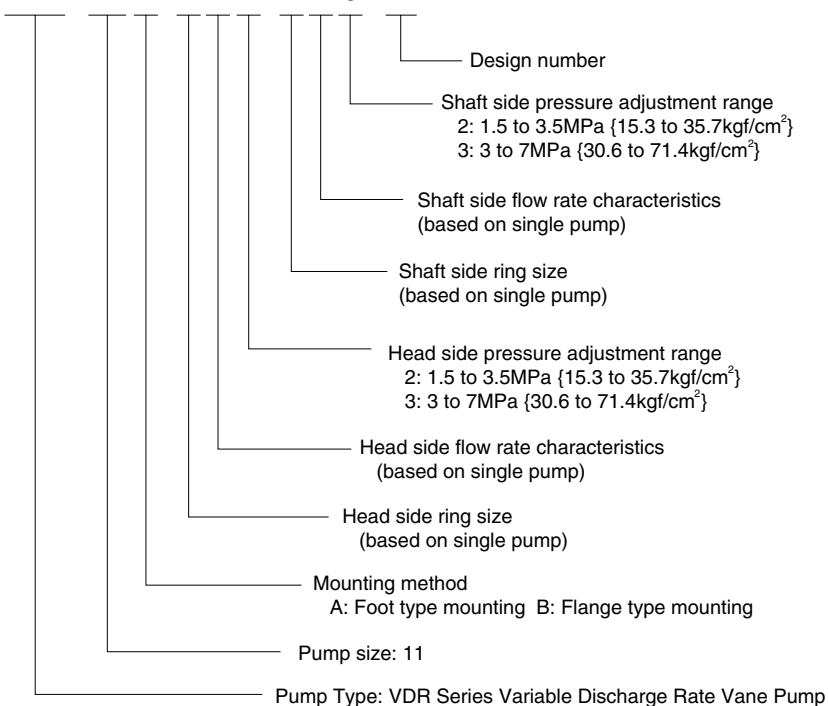

- 13 Provide a suction strainer with a filtering grade of about 100 μm (150 mesh). For the return line to the tank, use a 25 μm line filter.
- 14 Manage hydraulic operating fluid so contamination is maintained at class NAS10 or lower. Take care to avoid contamination with water or other foreign matter, and watch out for discoloration. Whitish fluid indicates that air has contaminated the fluid, and brown-

- ish fluid indicates the fluid is dirty.
- 15 Contact your agent about using water- and glycol-based hydraulic operating fluids.
- 16 At startup, repeat the inching operation (start-stop) to bleed air from the pump and pipes.
- 17 Equip an air bleed valve in circuits where it is difficult to bleed air before startup. See page C-13 for more information.

- 18 To ensure proper lubrication of the pump's rubbing surfaces, supply oil to the interior of the pump before starting operation.
- 19 When centering the pump shaft, eccentricity with the motor shaft should be no greater than 0.05mm. Use a pump mounting base of sufficient rigidity. The angle error should be no greater than 1°.

Installation Dimension Drawings

VDR-1A-*A*-22

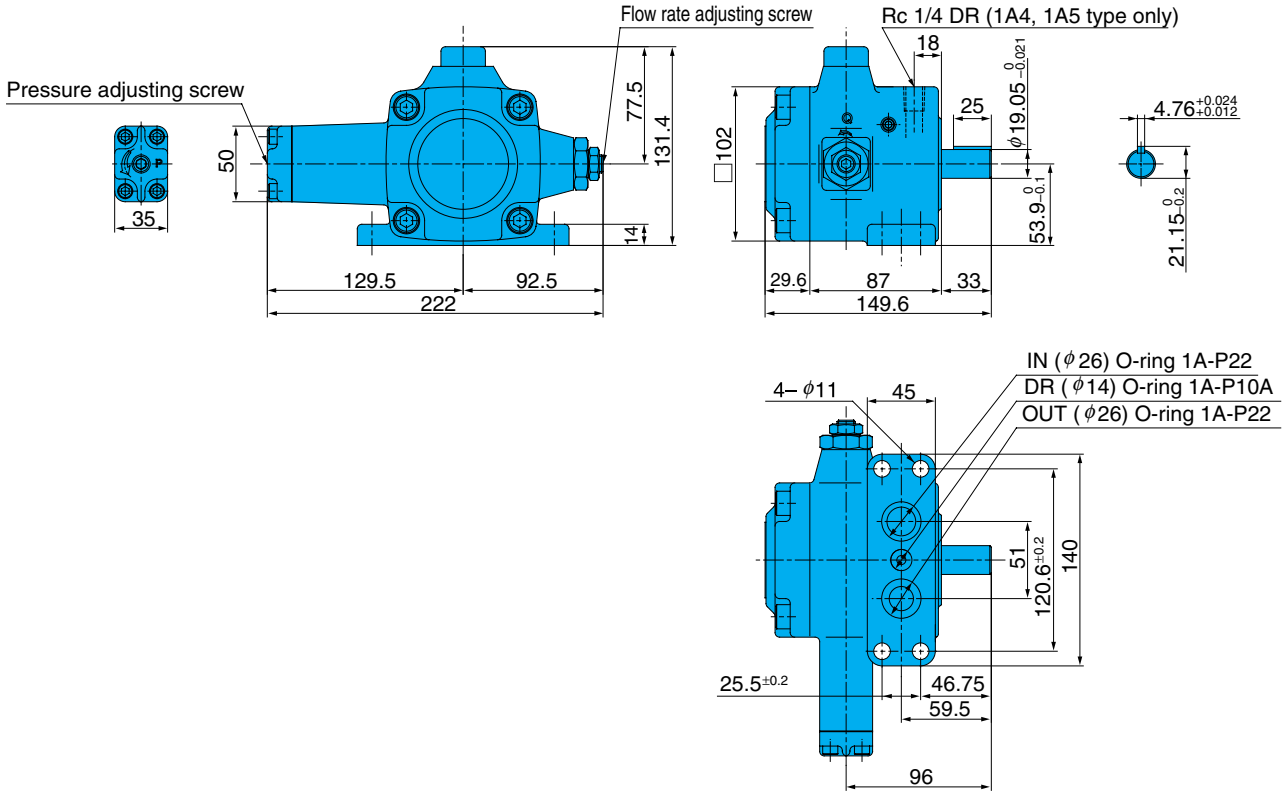

VDR-1B-*A*-22

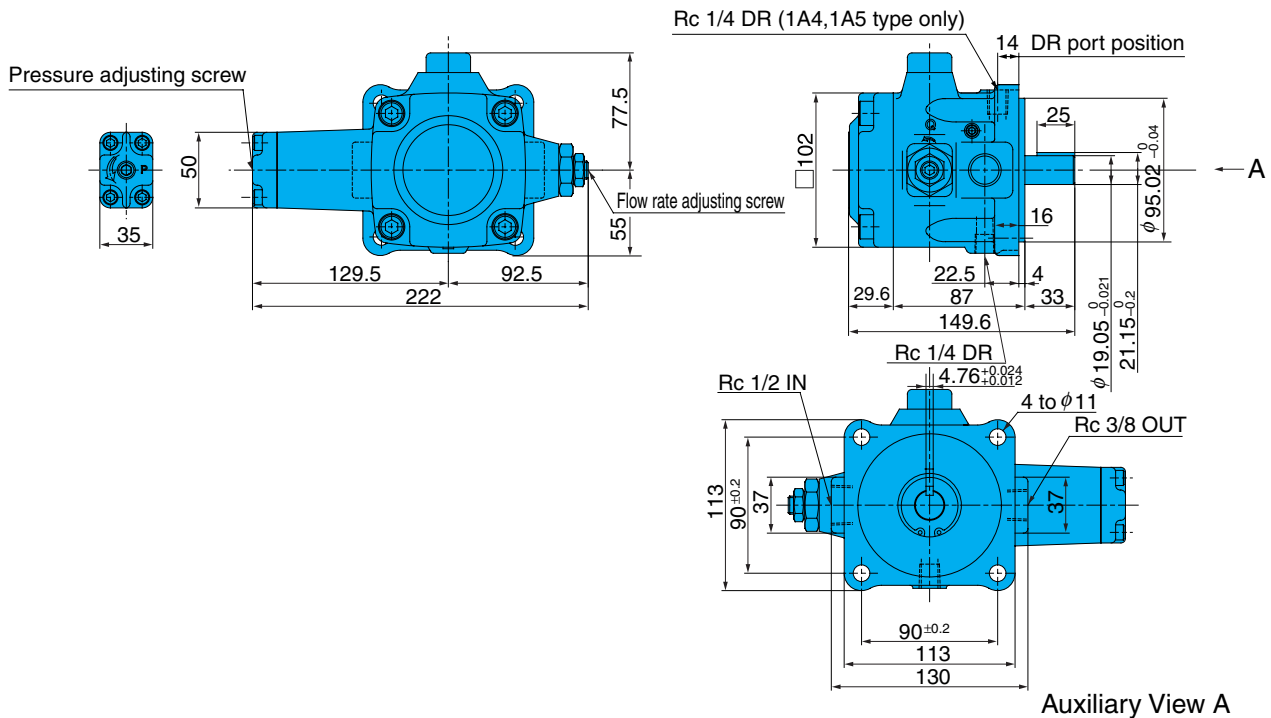

VDR-11A-*-*-22

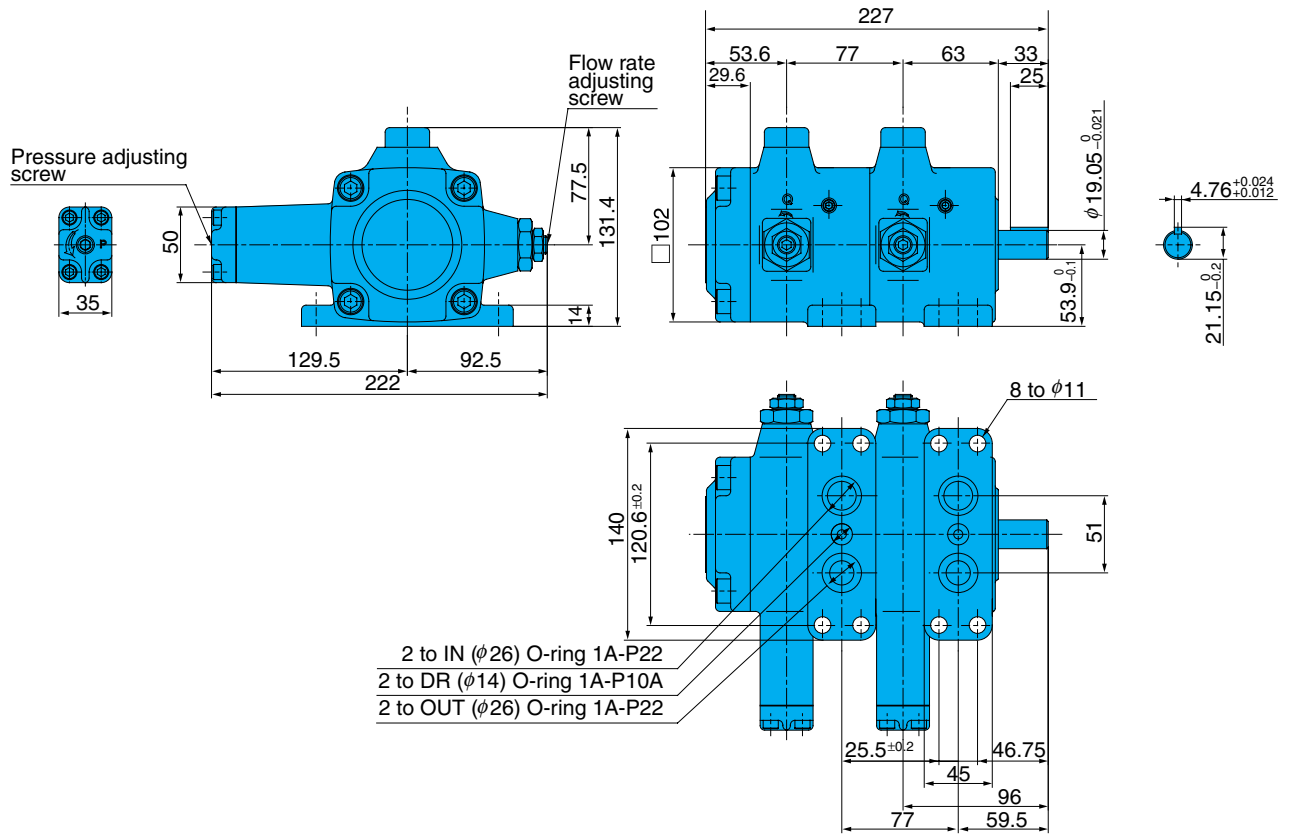

VDR-11B-*-*-22

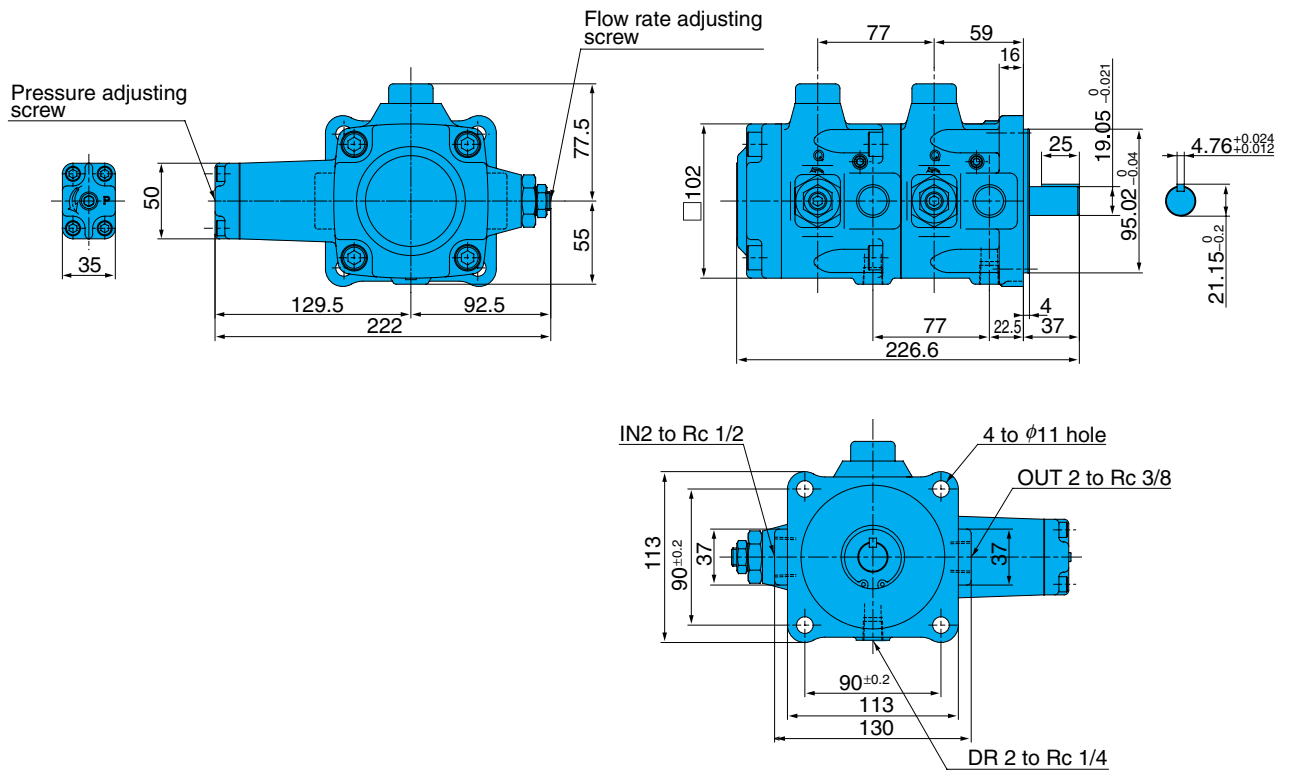

Performance Curves

Typical characteristics at hydraulic operating fluid kinematic viscosity of 32 mm²/s

VDR-1*-1A2-22

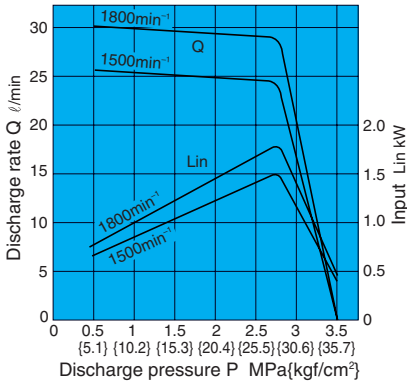

VDR-1*-1A3-22

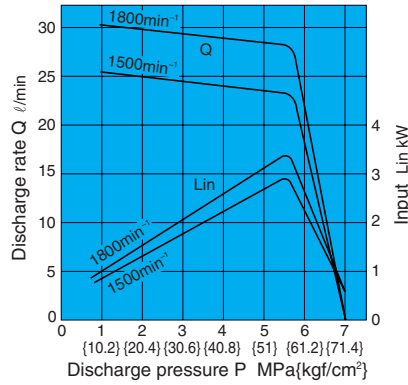

VDR-1*-1A4-22

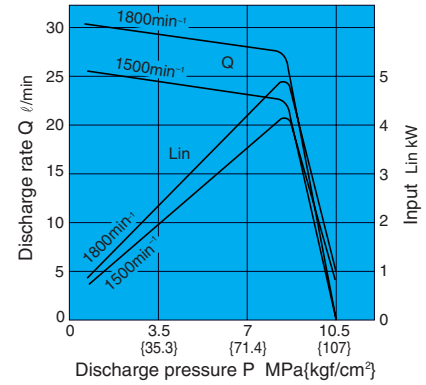

VDR-1*-1A5-22

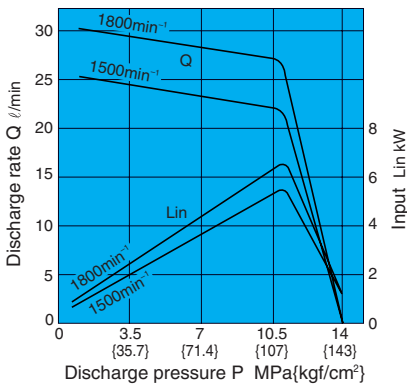

VDR-1*-2A2-22

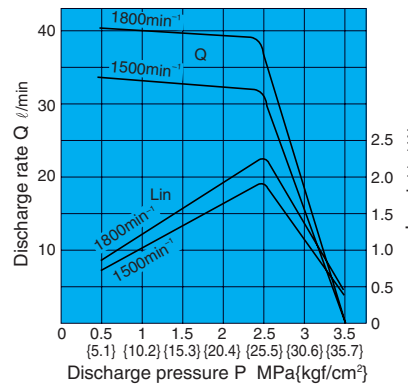

VDR-1*-2A3-22

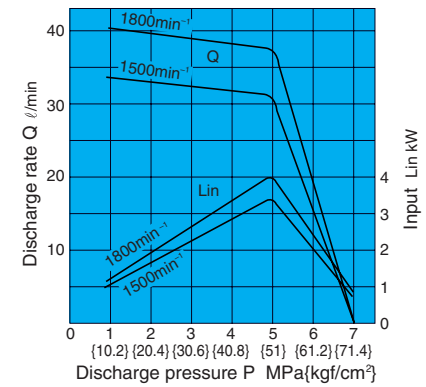

Axial Input At Full Cutoff

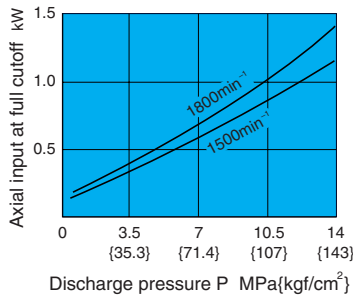

Noise Characteristics

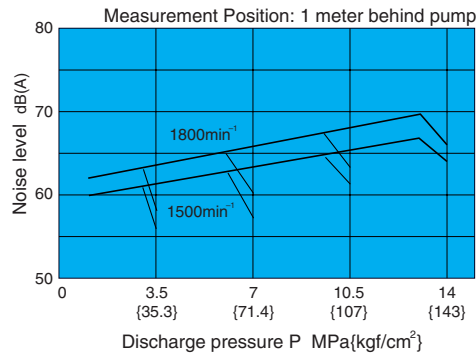

Cross-sectional Drawing

VDR-1A-*A*-22

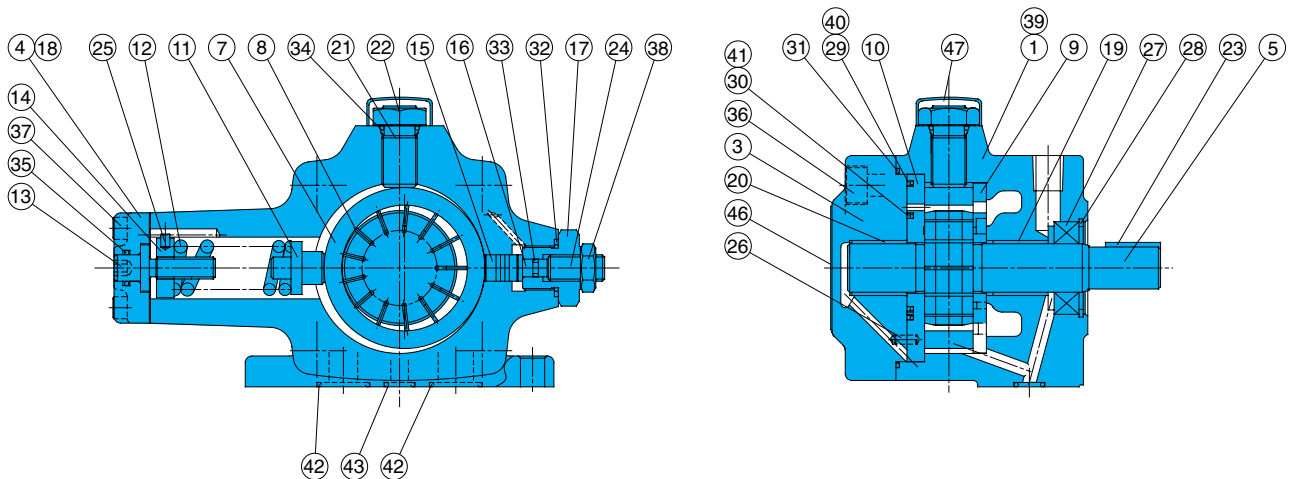

List of Sealing Parts

Single Pump

Part No.	Applicable Pump Model No. VDR-1A-*A*-22		
	Seal Kit Number VDBS-101A00		
	Part Name	Part Number	Q'ty
18	Packing	VDB32-101000	1
27	Oil seal	ISRD-224211	1
29	Backup ring	VDB34-101000	1
30	Backup ring	VDB34-201000	1
31	O-ring	S85(NOK)	1
32	O-ring	1A-P22	1
33	O-ring	1A-P5	1
34	O-ring	1A-P14	1
35	O-ring	1A-P12	1
40	O-ring	AS568-036	1
41	O-ring	AS568-029	1
42	O-ring	1A-P22	2
43	O-ring	1A-P10A	1

Note)

- Oil seals are manufactured by Nippon Oil Seal Industry Co. Ltd. (NOK).
- O-ring 1A-** refers to JIS B2401-1A-**.
- For VDR-1B-*A*-22, the seal kit number becomes VDBS-101B00, without the 42 and 43 O-rings.

Double Pump

Part Name	Applicable Pump Model No. VDR-11A-*A*-22		
	Seal Kit Number VDBS-111A00		
	Part Name	Part Number	Q'ty
18	Packing	VDB32-101000	2
27	Oil seal	ISRD-224211	1
29	Backup ring	VDB34-101000	2
30	Backup ring	VDB34-201000	2
31	O-ring	S85(NOK)	2
32	O-ring	1A-P22	2
33	O-ring	1A-P5	2
34	O-ring	1A-P14	2
35	O-ring	1A-P12	2
40	O-ring	AS568-036	2
41	O-ring	AS568-029	2
42	O-ring	1A-P22	4
43	O-ring	1A-P10A	2

Note)

- Oil seals are manufactured by Nippon Oil Seal Industry Co. Ltd. (NOK).
- O-ring 1A-** refers to JIS B2401-1A-**.
- For VDR-11B-*A*-22, the seal kit number becomes VDBS-111B00, without the 42 and 43 O-rings.

Part No.	Part Name	Part No.	Part Name
1	Body (A)	25	Pin
2	Body (B)	26	Spring pin
3	Cover	27	Oil seal
4	Cover	28	Snap ring
5	Shaft	29	Backup ring
6	Rotor	30	Backup ring
7	Ring	31	O-ring
8	Vane	32	O-ring
9	Plate (S)	33	O-ring
10	Plate (H)	34	O-ring
11	Piston	35	O-ring
12	Spring	36	Screw
13	Screw	37	Screw
14	Nut	38	Nut
15	Piston	39	Plug
16	Holder	40	O-ring
17	Adapter	41	O-ring
18	Packing	42	O-ring
19	Bearing (S)	43	O-ring
20	Bearing (H)	44	Screw
21	Thrust screw	45	Key
22	Nut	46	Nameplate
23	Key	47	Cap
24	Screw	48	Pin

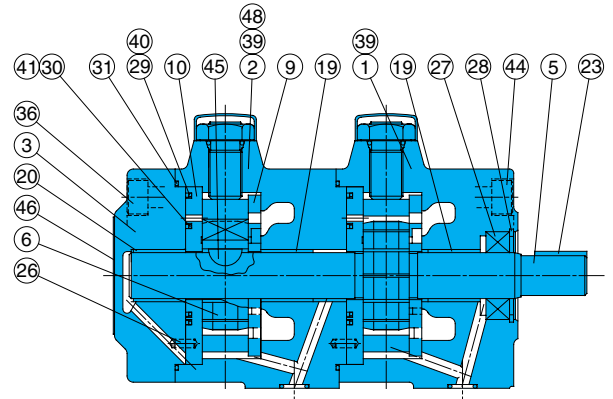
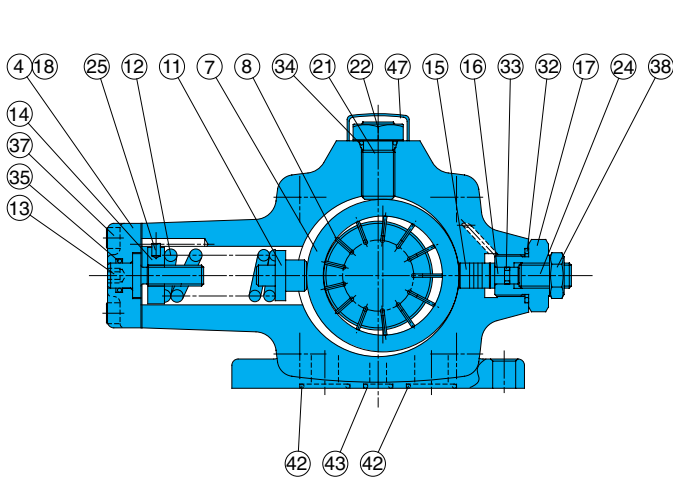

Uni-pump Specifications

(CE mark standard compliant)

Understanding Model Numbers

Single Pump

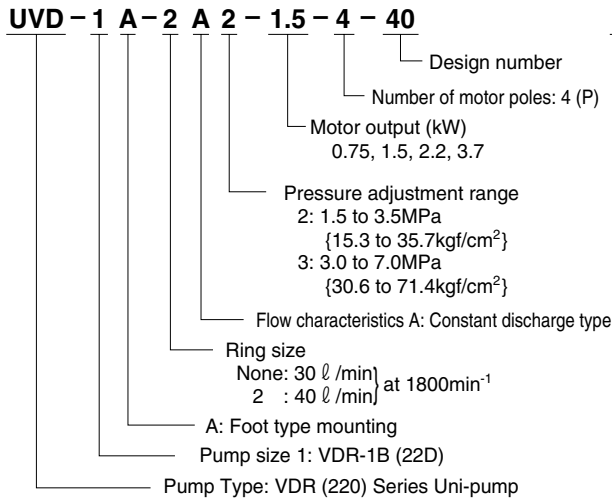

Double Pump

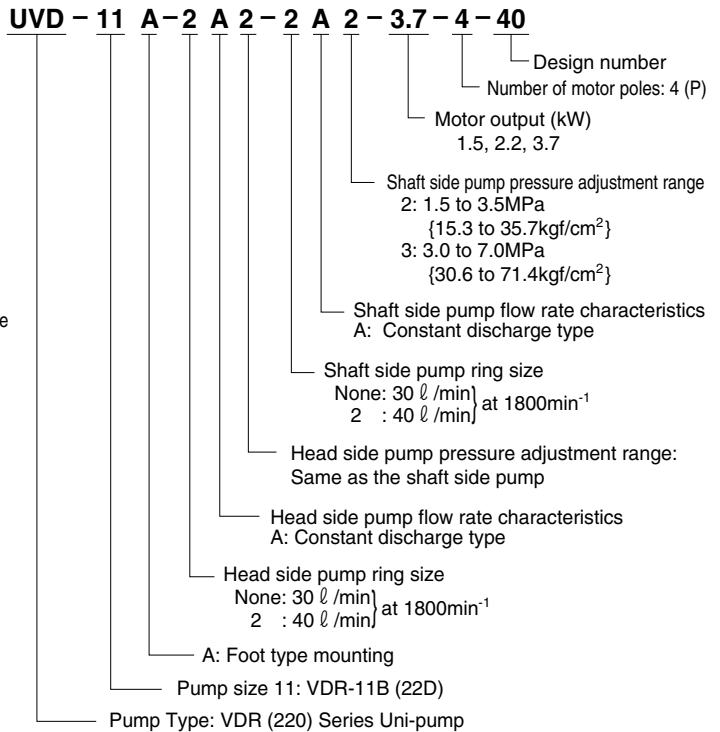

Specifications

Model No.	Maximum Working Pressure MPa{kgf/cm ² }	Maximum Flow Rate l/min (A*)		Maximum Flow Rate l/min (2A*)	
		50Hz	60Hz	50Hz	60Hz
UVD- 1A	7{71.4}	25	30	33	39
UVD-11A	7{71.4}	25-25	30-30	33-33	39-39

Motor selection curves

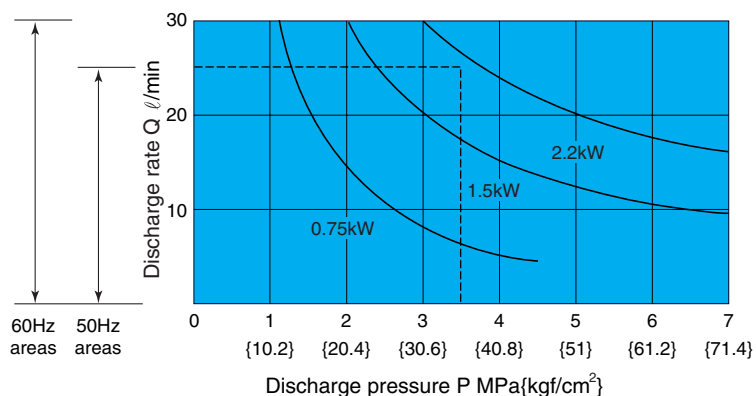

● **Selecting a motor**
The area under a motor output curve in the graph to the left is the operating range for that motor under the rated output for that motor.

Example:
To find the motor that can produce pressure of 3.5MPa and a discharge rate of 25 l/min.

Selection Process
Since the intersection of the two broken lines from a pressure of 3.5MPa and discharge rate of 25 l/min intersect in the area under the 2.2kW curve, it means that a 2.2kW motor should be used. In the case of a double pump configuration, select a motor that is larger than the total power required by both pumps.

* Select a uni-pump that has a pressure and flow rate that is within the range of the drive so that the drive will not overload.

Installation Dimension Drawings

UVD-1A

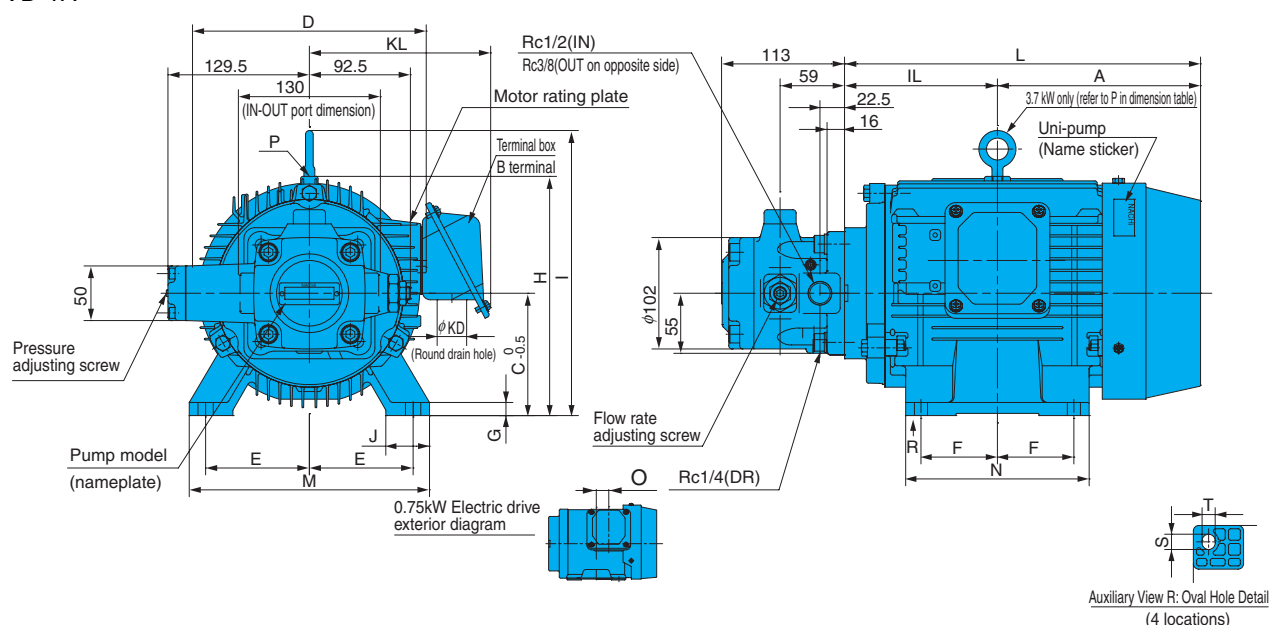

Uni-pump	Motor Dimensions mm																	Frame No.	Output kW (4 poles)	Weight kg
	A	IL	C	D	E	F	G	H	I	J	L	M	N	S × T	KD	KL	O			
UVD-1A-A2-0.75-4-40	133	105	80	170	62.5	50	4.5	165	-	35	238	165	130	18 × 10	φ27	157	27.5	80M	0.75	24
UVD-1A-A2-1.5-4-40	143	118.5	90	198	70	62.5	10	190	-	40	261.5	176	150	12 × 10	φ27	159	-	90L	1.5	25
UVD-1A-A3-1.5-4-40																				
UVD-1A-2A2-1.5-4-40	157.5	133	100	198	80	70	12	200	-	40	290.5	200	168	14 × 12	φ27	159	-	100L	2.2	30
UVD-1A-A2-2.2-4-40																				
UVD-1A-A3-2.2-4-40																				
UVD-1A-2A2-2.2-4-40																				
UVD-1A-A3-3.7-4-40	186	140	112	214	95	70	12	-	261	40	326	220	168	14 × 12	φ27	166	-	112M	3.7	36
UVD-1A-2A2-3.7-4-40																				
UVD-1A-2A3-3.7-4-40																				

0.75 to 2.2kW model does not have hangers.

- Standard drive motor is the fully enclosed fan-cooled B type.
- Standard voltage for drive motor is 200 VAC, 50/60 Hz or 220 VAC, 60 Hz.
- Standard terminal box is B terminal (right side viewed from pump).
- See page A-21 for the characteristics of the drive motor for the unipump (domestic standard 3 rating).

UVD-11A

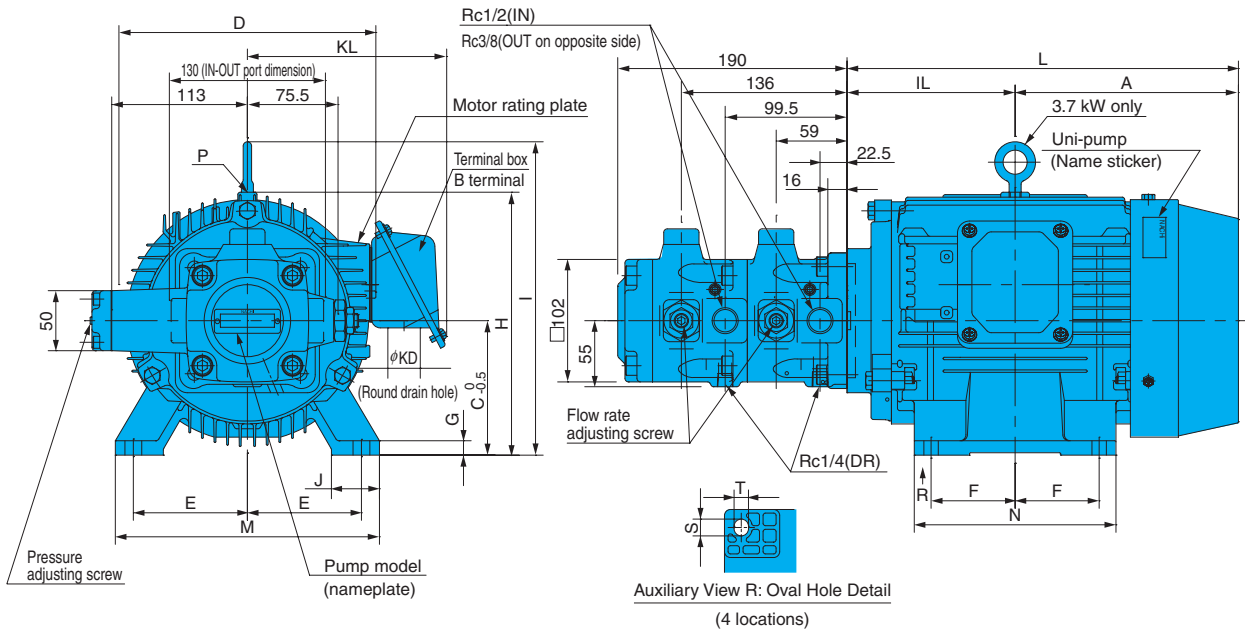

Uni-pump	Motor Dimensions mm																Frame No.	Output kW (4 poles)	Weight kg	
	A	IL	C	D	E	F	G	H	I	J	L	M	N	S × T	KD	KL				O
UVD-11A-A2-A2-1.5-4-40	143	118.5	90	198	70	62.5	10	190	-	40	261.5	176	150	12 × 10	φ27	159	-	90L	1.5	33
UVD-11A-A2-A3-1.5-4-40																				
UVD-11A-A3-A3-1.5-4-40																				
UVD-11A-A2-A2-2.2-4-40	157.5	133	100	198	80	70	12	200	-	40	290.5	200	168	14 × 12	φ27	159	-	100L	2.2	38
UVD-11A-A2-A3-2.2-4-40																				
UVD-11A-A3-A3-2.2-4-40																				
UVD-11A-2A2-2A2-2.2-4-40	186	140	112	214	95	70	12	-	261	40	326	220	168	14 × 12	φ27	166	-	112M	3.7	44
UVD-11A-A2-A2-3.7-4-40																				
UVD-11A-A2-A3-3.7-4-40																				
UVD-11A-A3-A3-3.7-4-40																				
UVD-11A-2A2-2A2-3.7-4-40																				
UVD-11A-2A2-2A3-3.7-4-40																				

1.5 to 2.2kW model does not have hangers.

1. Standard drive motor is the fully enclosed fan-cooled B type.
2. Standard voltage for drive motor is 200 VAC, 50/60 Hz or 220 VAC, 60 Hz.
3. Standard terminal box is B terminal (right side viewed from pump).
4. See page A-21 for the characteristics of the drive motor for the unipump (domestic standard 3 rating).