



### Relief Modular Valve

50 to 300 ℓ /min  
25,35MPa

### Features

- ① This modular relief valve provides maximum pressure control for a hydraulic circuit.
- ② Wide ranging applicability Maximum Operating Pressure: 25, 35MPa {255, 357kgf/cm<sup>2</sup>} Pressure Adjustment Range: 0.8 to 25, 35MPa {8.2 to 255, 357kgf/cm<sup>2</sup>}
- ③ Shockless unload, 2-pressure control, and other configurations are possible by switching the solenoid valve. Contact your agent for details.

### Specifications

Model No.	Nominal Diameter (Size)	Maximum Working Pressure MPa{kgf/cm <sup>2</sup> }	Maximum Flow Rate ℓ /min	Pressure Adjustment Range MPa{kgf/cm <sup>2</sup> }	Weight kg	Gasket Surface Dimensions
OR-G01-P1-20 P3	1/8	25 {255}	50	* to 7{ * to 71.4} 3.5 to 25{35.7 to 255}	1.5	ISO 4401-03-02-0-94
OR-G01-W1-20 W3				* to 7{ * to 71.4} 3.5 to 25{35.7 to 255}	2.3	
OR-G01-A1-21 A3				* to 7{ * to 71.4} 3.5 to 25{35.7 to 255}	1.6	
OR-G01-B1-21 B3				* to 7{ * to 71.4} 3.5 to 25{35.7 to 255}	1.6	
OR-G03-P1-(V)-J50 P3	3/8	25 {255}	80	* to 7{ * to 71.4} 3.5 to 25{35.7 to 255}	3.1	ISO 4401-05-04-0-94
OR-G03-W1-J50 W3				* to 7{ * to 71.4} 3.5 to 25{35.7 to 255}	3.9	
OR-G03-A1-J50 A3				* to 7{ * to 71.4} 3.5 to 25{35.7 to 255}	3.1	
OR-G03-B1-J50 B3				* to 7{ * to 71.4} 3.5 to 25{35.7 to 255}	3.1	
ORH-G04-P1-10 P3 P5	1/2	35 {357}	300	* to 7{ * to 71.4} 3.5 to 25{35.7 to 255} 7 to 35{71.4 to 357}	7.0	ISO 4401-07-06-0-94

Note) \*See the Flow Rate - Low Pressure characteristics on page D-17 for information about items marked with an asterisk.

#### ● Handling

- ① When using a remote control valve in a vent circuit, certain vent circuit pipe capacities can cause vibration. Because of this, thick steel pipe with an inside diameter of  $\phi 4$ mm that is no longer than three meters is recommended. Vent piping cannot be used with the 01 size. If a vent port is required for the 03 size, add the auxiliary code "V".
- ② For use as a safety valve, use a pressure override that is higher than the required circuit pressure.
- ③ Make sure that tank port back pressure is no greater than 0.2MPa {2.0kgf/cm<sup>2</sup>}.
- ④ A small control flow rate can cause pressure instability. Use a control flow rate that is in accordance with the values shown below.  
01 size: At least 5 ℓ /min  
03 size: At least 8 ℓ /min  
04 size: At least 8 ℓ /min  
For applications that require a flow rate that is less than the minimum flow rate, use an ORD-G\*\* direct type relieve modular valve.
- ⑤ Note that a sub plate and installation bolts are not included. See pages D-90 through D-95 if these items are required.
- ⑥ 04 series modular valves do not have an L (DR<sub>2</sub>) drain port, so they cannot be used in combination with pressure center type solenoid valves (D).
- ⑦ Connect OR-G03-W\*-(J) 50 to the two T-ports on the tanks.

## Understanding Model Numbers

01: 03 size

**OR-G 03 - P 1 - (K) - J50**

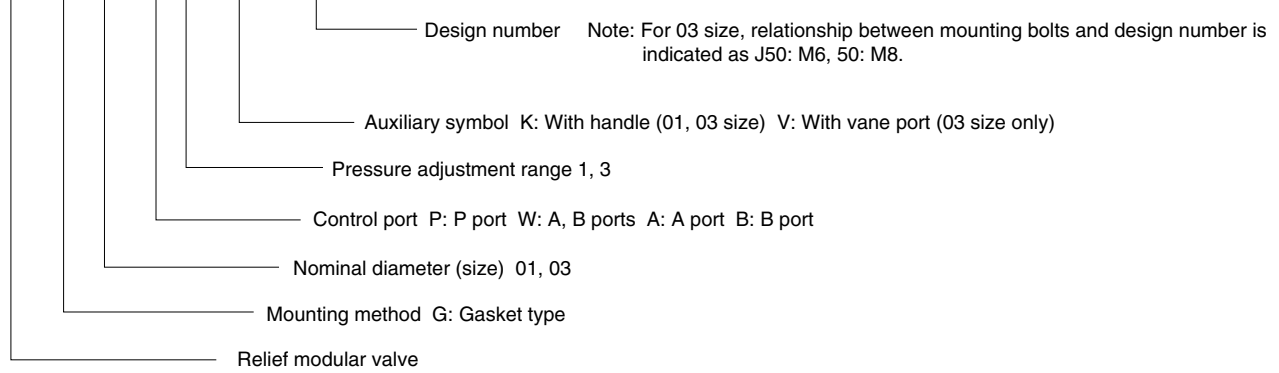

## Understanding Model Numbers

04 size

**ORH-G 04 - P 5 - 10**

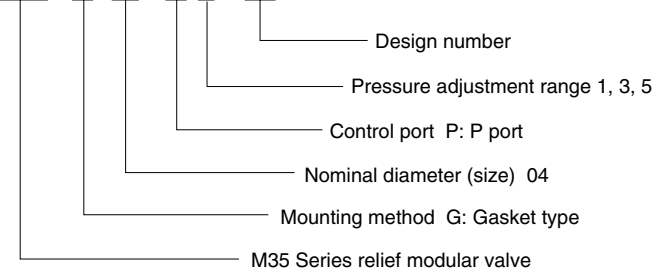

## Installation Dimension Drawings

Note) Pressure is increased by clockwise (rightward) rotation of the adjusting screw (bolt), and decreased by counterclockwise (leftward) rotation.

OR-G01-P\*-20

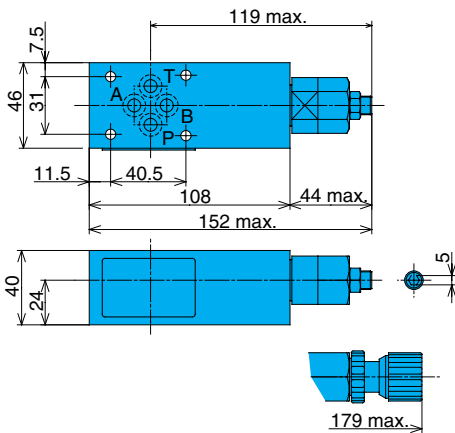

OR-G01-W\*-20

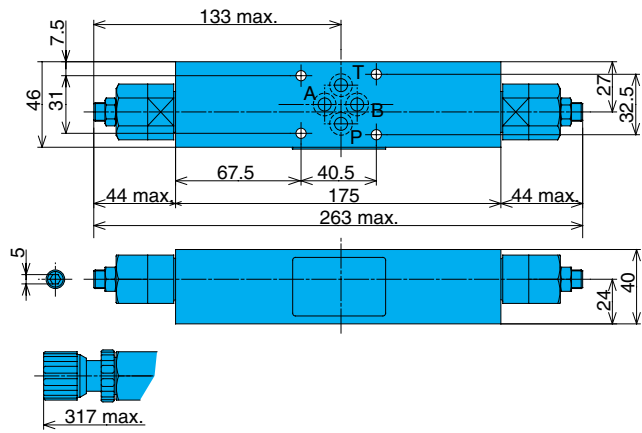

OR-G01-A\*-21

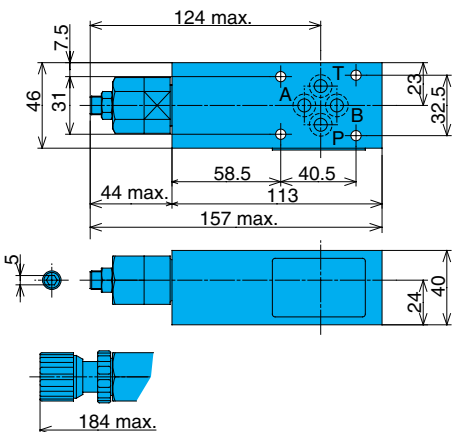

OR-G01-B\*-21

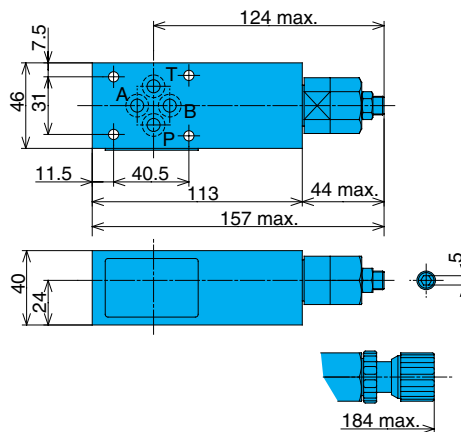

OR-G03-P\*-(V)-J50

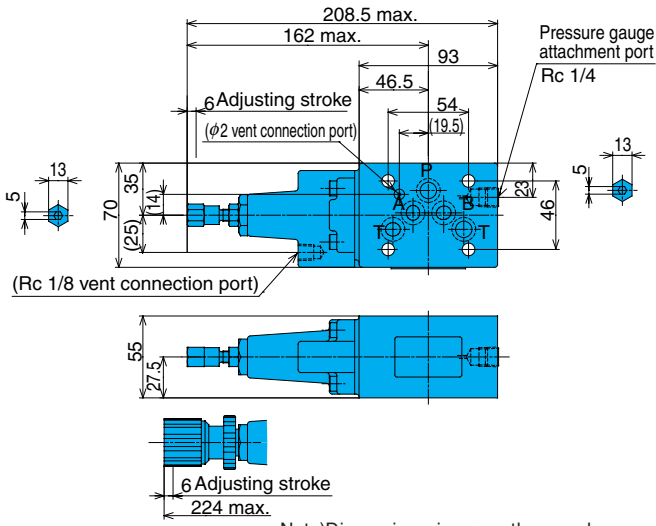

OR-G03-W\* -J50

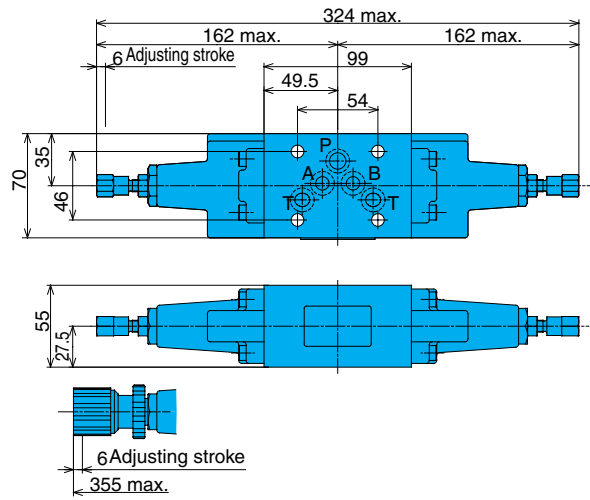

Note) Dimensions in parentheses show dimensions with vent port installed (V type)

OR-G03-A\* -J50

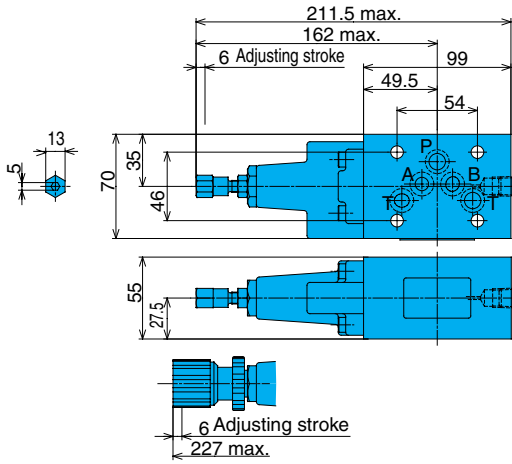

OR-G03-B\* -J50

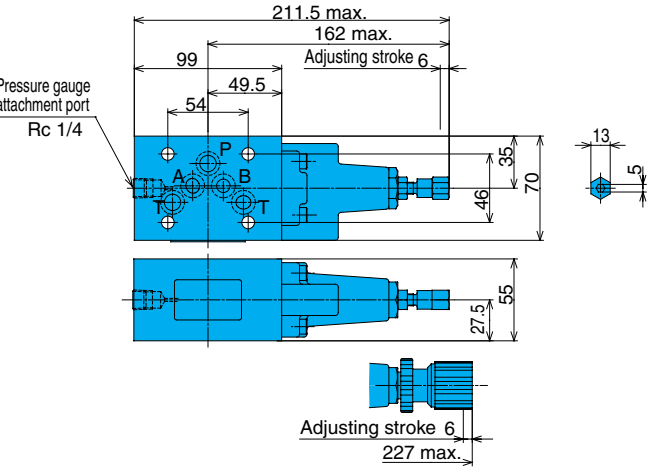

ORH-G04-P\* -10

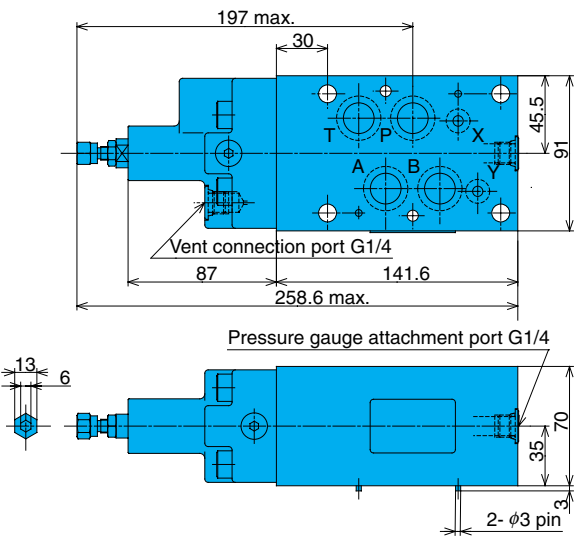

# Performance Curves

Differential Hydraulic Fluid Viscosity 32mm<sup>2</sup>/s

Flow Rate – Minimum Pressure Characteristics

OR-G01-\*1-20(21)

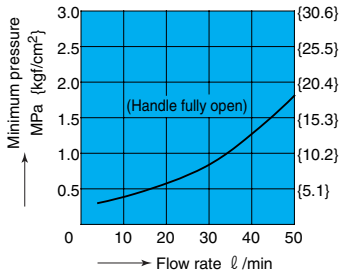

OR-G03-P1-J50

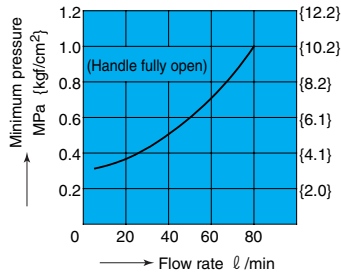

ORH-G04-P\*-10

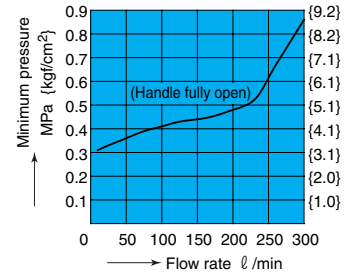

Pressure – Flow Rate Characteristics

OR-G01-\*\*-20(21)

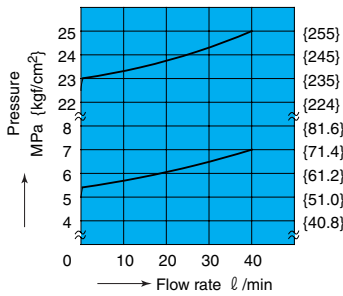

OR-G03-P\*-J50

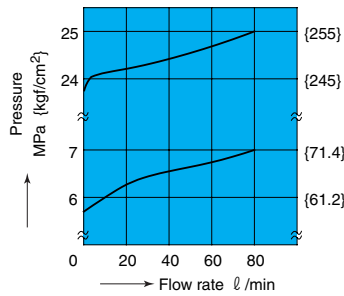

ORH-G04-P\*-10

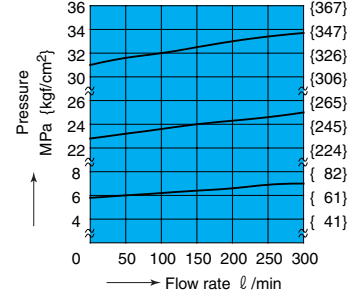

Number of Adjusting Screw Rotations – Pressure Characteristics

OR-G01-P\*-20

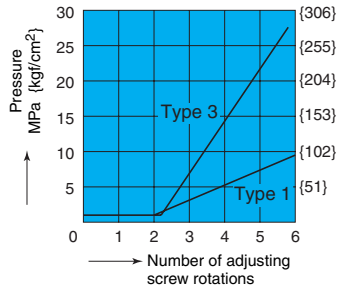

OR-G03-P\*-(J)50

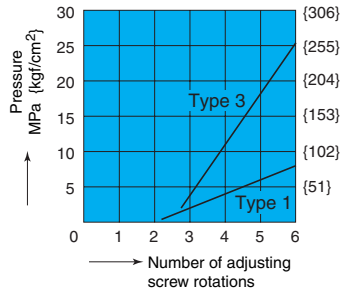

ORH-G04-P\*-10

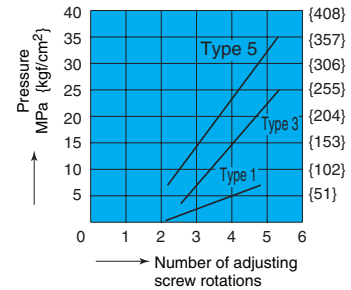

D

Modular Valves

## Cross-sectional Drawing

OR-G01-P\*-20

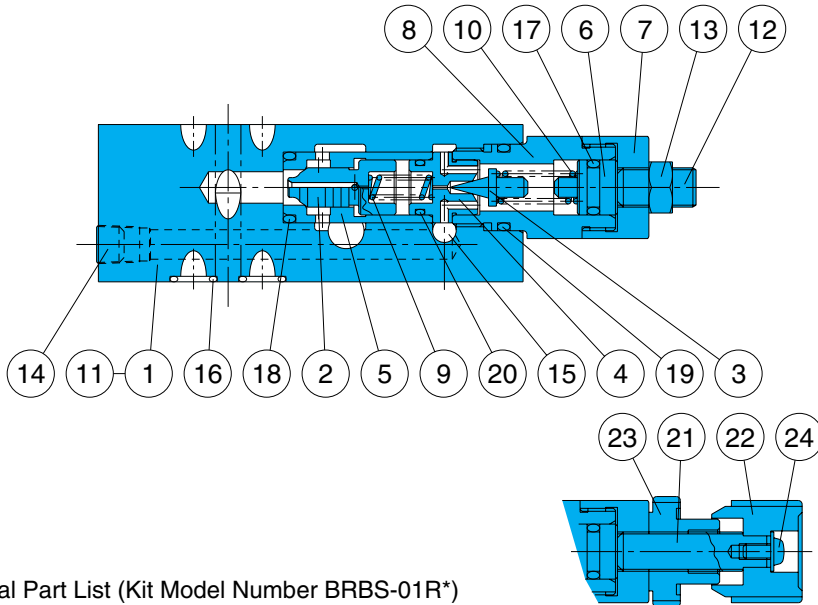

Part No.	Part Name
1	Body
2	Spool
3	Poppet
4	Seat
5	Sleeve
6	Plunger
7	Bushing
8	Retainer
9	Spring
10	Spring
11	Plate
12	Screw
13	Nut
14	Plug
15	Plug
16	O-ring
17	O-ring
18	O-ring
19	O-ring
20	O-ring
21	Screw
22	Knob
23	Nut
24	Screw

Seal Part List (Kit Model Number BRBS-01R\*)

Part No.	Part Name	Part Number	Q'ty			
			P	W	A	B
16	O-ring	1B-P9	4	4	4	4
17	O-ring	1A-P10A	1	2	1	1
18	O-ring	1B-P14	1	2	1	1
19	O-ring	1B-P18	1	2	1	1
20	O-ring	AS568-013(Hs90)	1	2	1	1

Note) 1. O-ring 1A/B-\*\* refers to JIS B2401-1A/B.  
2. Specify P, W, A, or B for the asterisk (\*) in the kit model number.

OR-G03-P\*-V-J50

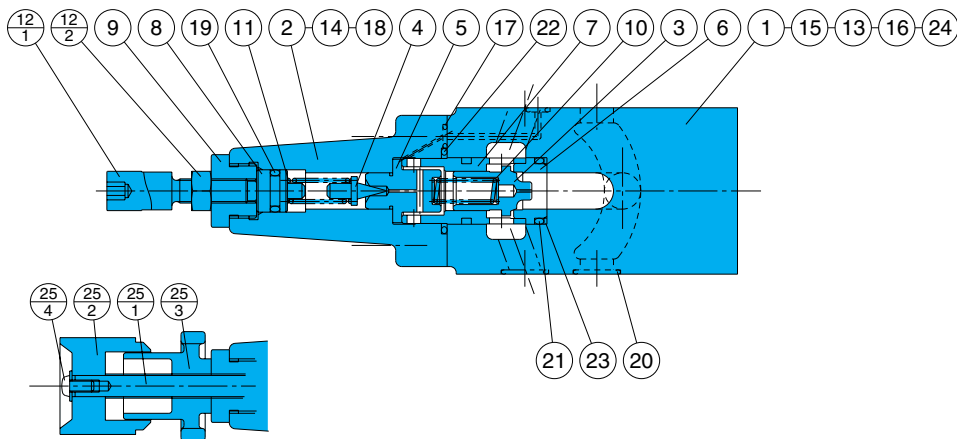

Part No.	Part Name
1	Body
2	Cover
3	Spool
4	Poppet
5	Seat
6	Seat
7	Sleeve
8	Plunger
9	Retainer
10	Spring
11	Spring
12	Screw kit
12 <sub>1</sub>	Screw
12 <sub>2</sub>	Nut
13	Plate
14	Screw
15	Plug
16	Plug
17	O-ring
18	O-ring
19	O-ring
20	O-ring
21	O-ring
22	O-ring
23	Backup ring
24	Pin
25	Handle kit
25 <sub>1</sub>	Screw
25 <sub>2</sub>	Knob
25 <sub>3</sub>	Nut
25 <sub>4</sub>	Screw

Seal Part List (Kit Model Number BRES-03R\*)

Part No.	Part Name	Part Number	Q'ty		
			P/A/B	W	PV
17	O-ring	1B-P5	—	—	2
18	O-ring	1B-P7	1	2	1
19	O-ring	1A-P10A	1	2	1
20	O-ring	AS568-014(Hs90)	5	5	5
21	O-ring	1B-P18	2	4	2
22	O-ring	AS568-119(Hs90)	1	2	1
23	Backup ring	T2-P18	1	2	1

Note) 1. O-ring 1A/B-\*\* refers to JIS B2401-1A/B.  
2. Backup ring indicates JIS B2407-T2-\*\*.  
3. Specify P, W, or PV for the asterisk (\*) in the kit model number.

ORH-G04-P\*-10

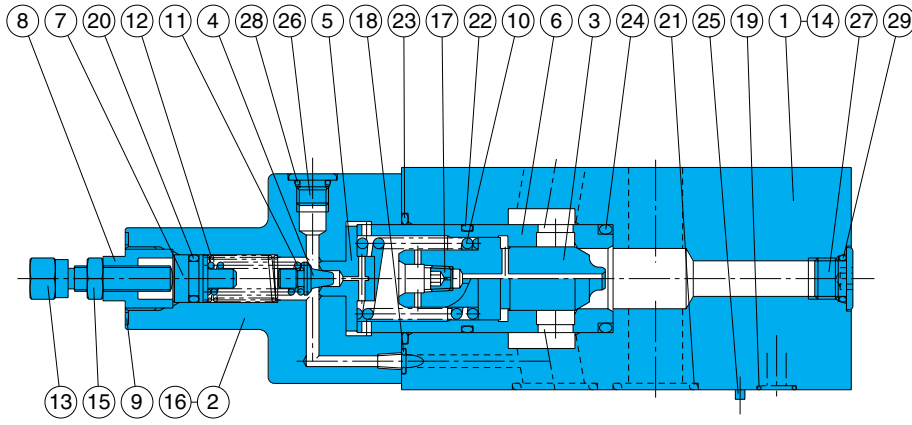

Part No.	Part Name
1	Body
2	Cover
3	Spool
4	Poppet
5	Seat
6	Sleeve
7	Plunger
8	Retainer
9	Plate
10	Spring
11	Spring
12	Spring
13	Screw
14	Plate
15	Nut
16	Screw
17	Choke
18	O-ring
19	O-ring
20	O-ring
21	O-ring
22	O-ring
23	O-ring
24	O-ring
25	Pin
26	Plug
27	Plug
28	O-ring
29	O-ring

Seal Part List (Kit Model Number BRKS-04RP)

Part No.	Part Name	Part Number	Qty
18	O-ring	1B-P5	1
19	O-ring	AS568-012(Hs90)	2
20	O-ring	1A-P11	1
21	O-ring	AS568-118(Hs90)	4
22	O-ring	AS568-122(Hs90)	1
23	O-ring	AS568-127(Hs90)	1
24	O-ring	1B-P28	1
28	O-ring	1B-P8	3
29	O-ring	1B-P11	3

Note) O-ring 1A/B-\*\* refers to JIS B2401-1A/B.