



Balanced Piston Type Pressure Reducing Modular Valve

40 ℓ /min
25MPa

Features

- ① This modular valve makes the pressure in part of the circuit lower than the main circuit.
- ② Even when pressure changes in the primary main circuit, the reduced secondary pressure is maintained at a constant level.
- ③ Compared with the direct type, this type of valve has outstanding Pressure-Flow Rate Characteristics, and a superior flow rate in the low pressure control range.
- ④ Maximum operating pressure: 25MPa {255kgf/cm²}

Specifications

Model No.	Nominal Diameter (Size)	Maximum Working Pressure MPa{kgf/cm ² }	Maximum Flow Rate ℓ /min	Pressure Adjustment Range MPa{kgf/cm ² }	Weight kg	Gasket Surface Dimensions
OGB-G01-PC-20 P1 P3	1/8	25 {255}	40	0.15 to 3.5{ 1.5 to 35.7}	1.9	ISO 4401-03-02-0-94
OGB-G01-AC-20 A1 A3				0.8 to 7{ 8.2 to 71.4}		
OGB-G01-BC-20 B1 B3				3.5 to 21{35.7 to 214}		

Understanding Model Numbers

OGB - G 01 - P 1 - (K) - 20

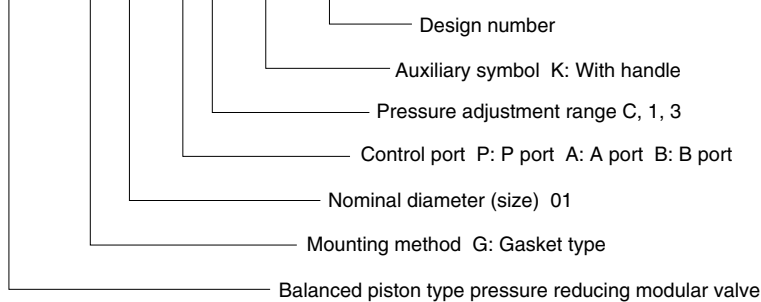

● Handling

- ① See the Pressure-Flow Rate Characteristics for information about how the flow rate is controlled at low pressures.
- ② Note that a change in tank port back pressure causes a change in setting pressure.
- ③ Vent piping is not possible.
- ④ Note that a sub plate and installation bolts are not included. See pages D-90 through D-95 if these items are required.

Installation Dimension Drawings

Note)

Pressure is increased by clockwise (rightward) rotation of the adjusting screw (bolt), and decreased by counterclockwise (leftward) rotation.

OGB-G01-P_A*-20

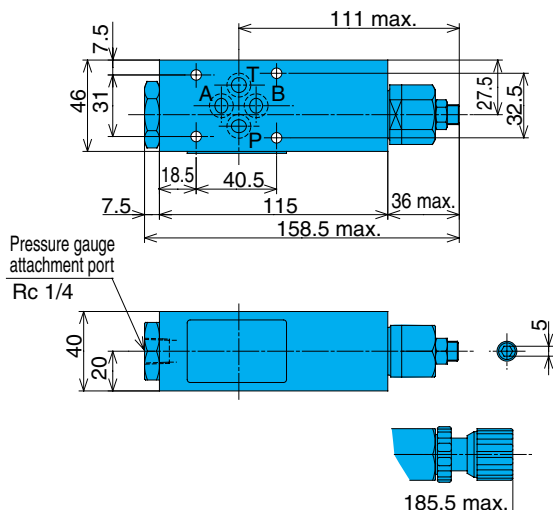

OGB-G01-B*-20

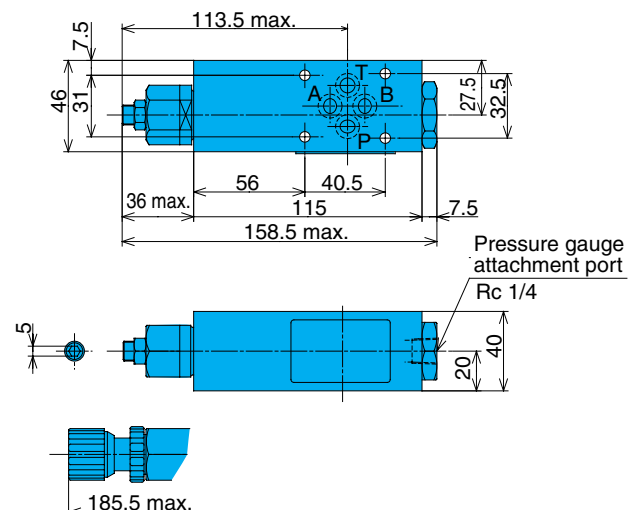

Performance Curves

Hydraulic Operating Fluid Viscosity 32mm²/s

Pressure Loss Characteristics

OGB-G01-P*-20

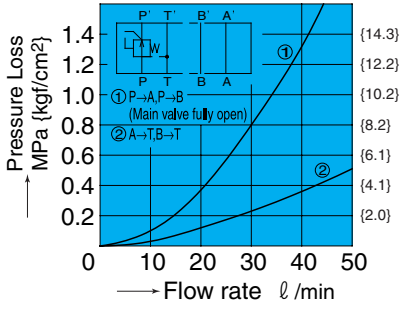

Pressure – Drain Rate Characteristics

OGB-G01-**-20

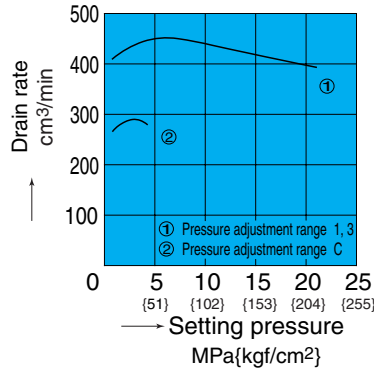

Number of Adjusting Screw Rotations – Pressure Characteristics

OGB-G01-P*-20

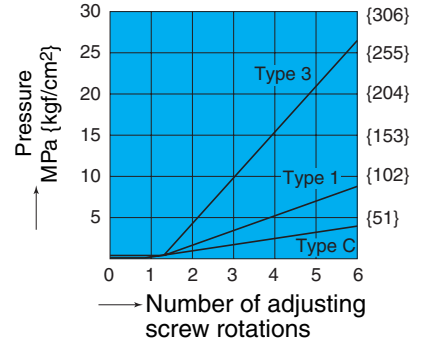

Pressure – Flow Rate Characteristics

OGB-G01-¹/₃-20

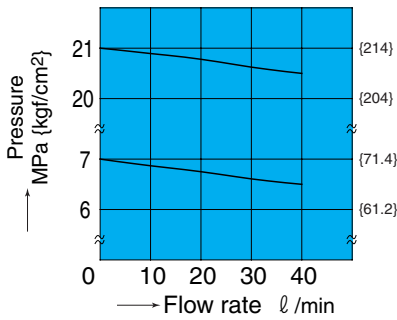

OGB-G01-*C-20

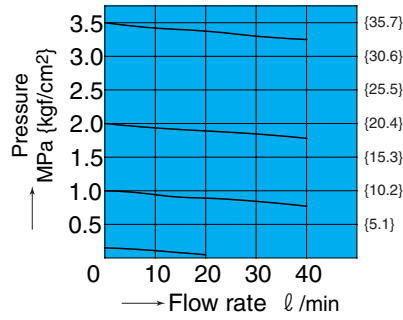

Cross-sectional Drawing

OGB-G01-P*-20

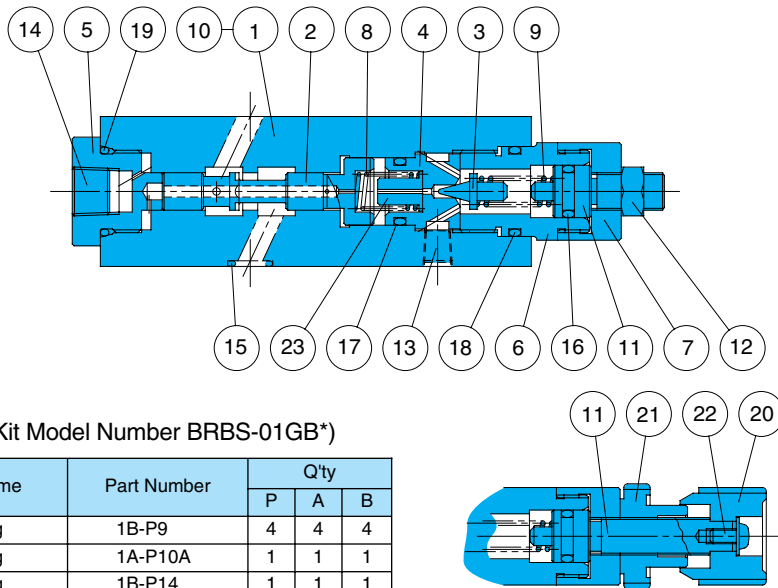

Seal Part List (Kit Model Number BRBS-01GB*)

Part No.	Part Name	Part Number	Q'ty		
			P	A	B
15	O-ring	1B-P9	4	4	4
16	O-ring	1A-P10A	1	1	1
17	O-ring	1B-P14	1	1	1
18	O-ring	1B-P20	1	1	1
19	O-ring	1B-P20	1	1	1

Note) 1.O-ring 1A/B-** refers to JIS B2401-1A/B.
2.Specify P, A, or B for the asterisk (*) in the kit model number.

Part No.	Part Name
1	Body
2	Spool
3	Poppet
4	Seat
5	Bushing
6	Retainer
7	Bushing
8	Spring
9	Spring
10	Plate
11	Screw
12	Nut
13	Plug
14	Plug
15	O-ring
16	O-ring
17	O-ring
18	O-ring
19	O-ring
20	Knob
21	Nut
22	Screw
23	Choke

D

Modular Valves