



Flow Regulator Modular Valve

50 to 300 ℓ /min
25,35MPa

Features

- ① This modular valve is used to control actuator speed and for other flow control valve applications.
- ② A wide range of models are available for A and B port control, A or B port control, and P or T port control.
- ③ Maximum Operating Pressure: 25, 35MPa {255, 357kgf/cm²}

Specifications

Model No.	Nominal Diameter (Size)	Maximum Working Pressure MPa{kgf/cm ² }	Maximum Flow Rate ℓ /min	Pressure Adjustment Range MPa{kgf/cm ² }	Weight kg	Gasket Surface Dimensions
OY-G01-T-20	1/8	25{255}	50	-	1.0	ISO 4401-03-02-0-94
OCY-G01-P-20				0.04{0.4}	1.0	
OCY-G01-W-X-20 A B				0.08{0.8}	1.3	
					1.2	
OCY-G01-W-Y-20 A B				0.08{0.8}	1.3	
	1.2					
OCY-G03-P-J50	3/8	25{255}	100	0.04{0.4}	2.9	ISO 4401-05-04-0-94
OCY-G03-W-X-J51 A B				0.1{1.0}	3.1	
					3.0	
OCY-G03-W-Y-J51 A B				0.1{1.0}	3.1	
	3.0					
OYH-G04-P-10	1/2	35{357}	300	0.04{0.4}	4.7	ISO 4401-07-06-0-94
OYH-G04-W-X-10 A B				0.1{1.0}	6.5	
					6.3	
OYH-G04-W-Y-10 A B				0.1{1.0}	6.5	
	6.3					

● Handling

- ① In a 03 size application where control differential pressure is large, use of an H type makes adjustment easier.
- ② Note that a sub plate and installation bolts are not included. See pages D-90 through D-95 if these items are required.
- ③ 04 series modular valves do not have an L (DR₂) drain port, so they cannot be used in combination with pressure center type solenoid valves (D).

Understanding Model Numbers

01, 03 size

OCY - G 03 - W - (H) Y - (K) - J51

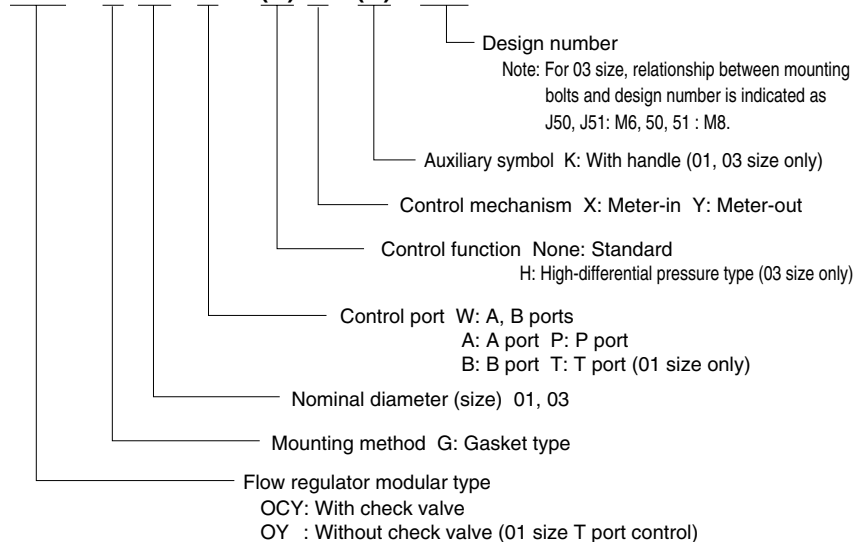

Understanding Model Numbers

04 size

OYH - G 04 - W - Y - 10

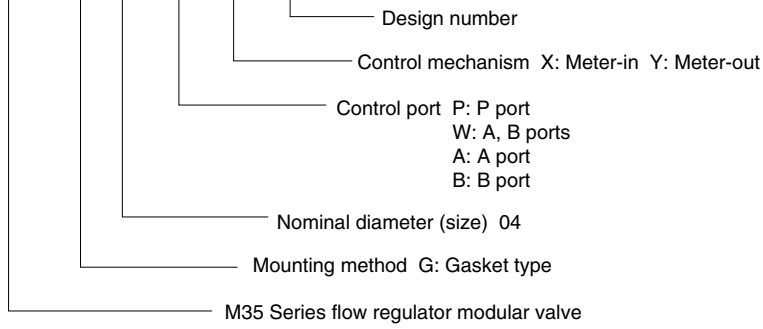

Installation Dimension Drawings

Note) The control flow rate is increased by counter clockwise (leftward) rotation of the adjusting screw.

OY-G01-T-20

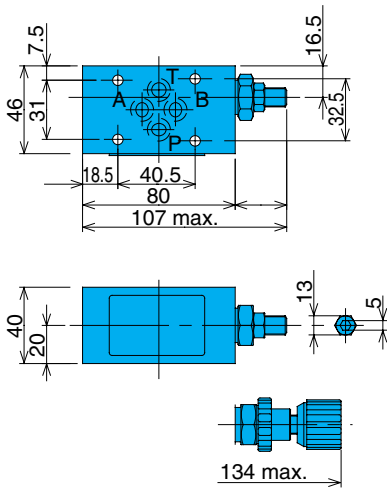

OCY-G01-P-20

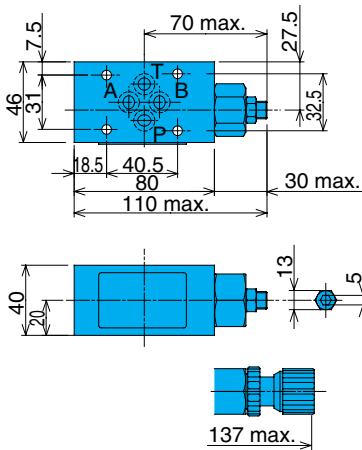

OCY-G01-W-X-20

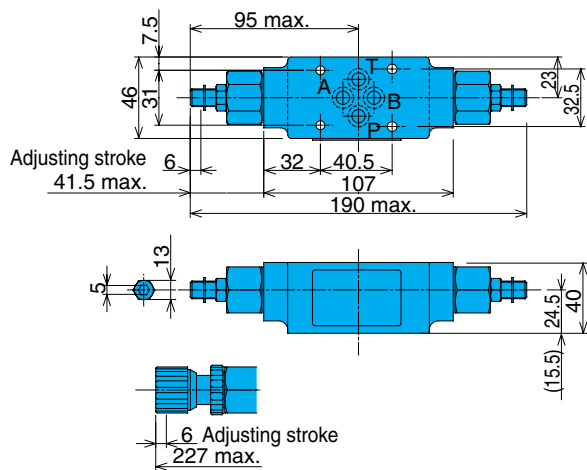

Note) Dimensions in the parentheses are for the OCY-G01-W-X-20.

OCY-G01-A-X_Y-20

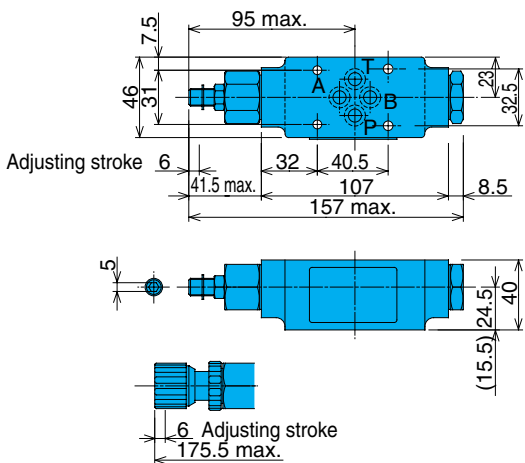

Note)
Dimensions in the parentheses are for the OCY-G01-A-X-20.

OCY-G01-B-X_Y-20

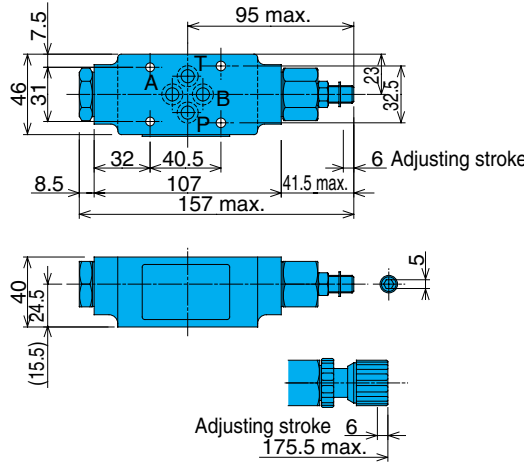

Note)
Dimensions in the parentheses are for the OCY-G01-B-X-20.

OCY-G03-P-J50

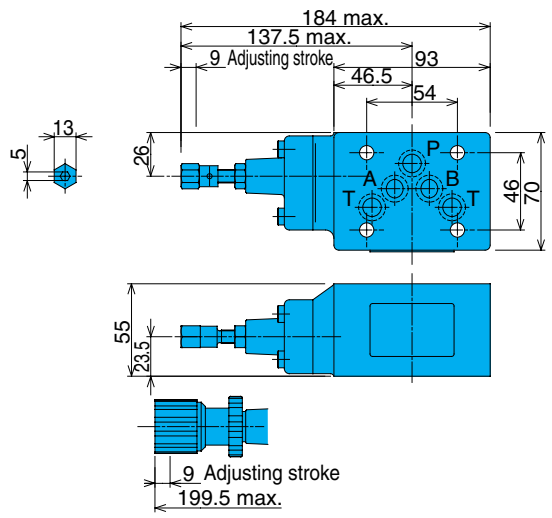

OCY-G03-W-X_Y-J51

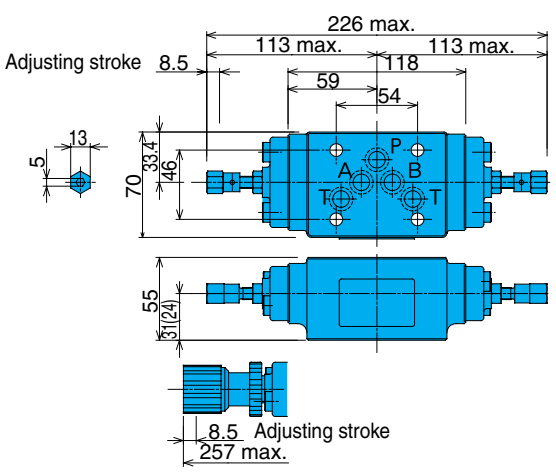

Note)
Dimensions in the parentheses are for the OCY-G03-W-X-J51.

OCY-G03-A-X_Y-J51

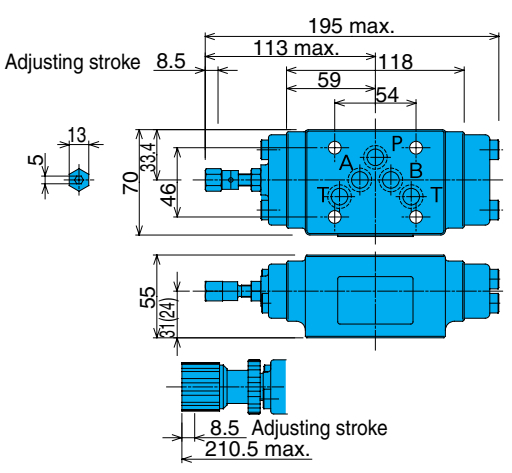

OCY-G03-B-X_Y-J51

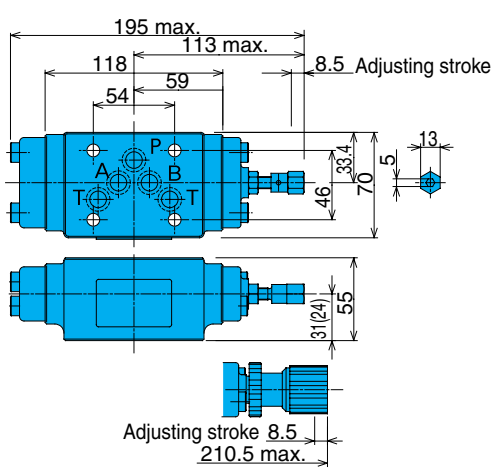

Note)
Dimensions in the parentheses are for the OCY-G03-B-X-J51.

Note)
Dimensions in the parentheses are for the OCY-G03-A-X-J51.

OYH-G04-P-10

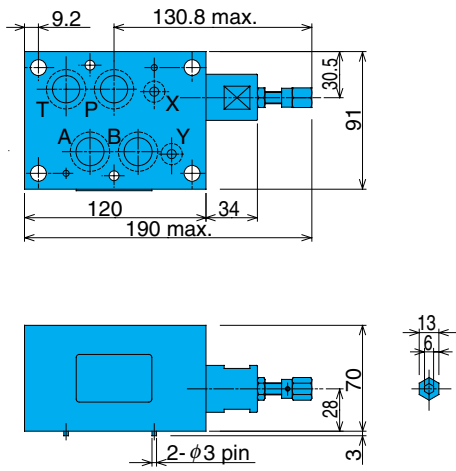

OYH-G04-W-X⁻Y-10

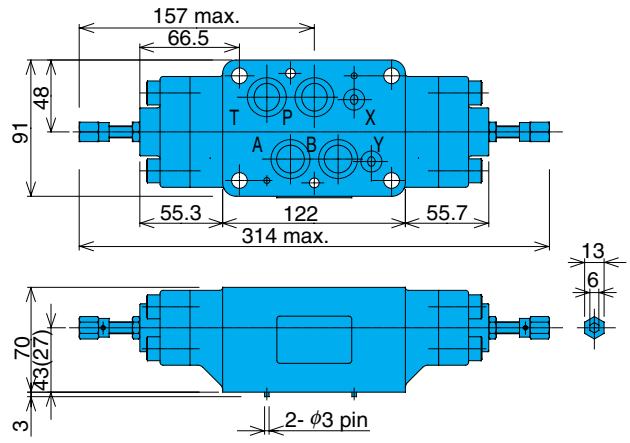

OYH-G04-A-X⁻Y-10

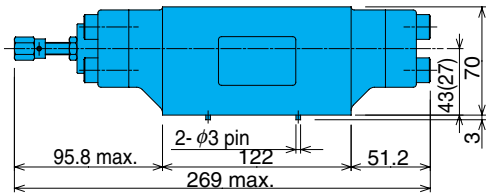

OYH-G04-B-X⁻Y-10

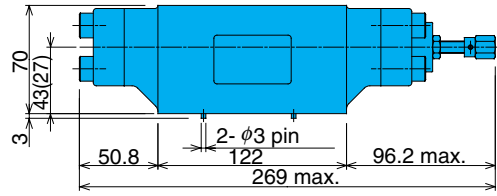

Note) Dimensions in the parentheses are for the OYH-G04-*X-10.

Performance Curves

Hydraulic Operating Fluid Viscosity 32mm²/s

Pressure Loss Characteristics

OY-G01-T-20

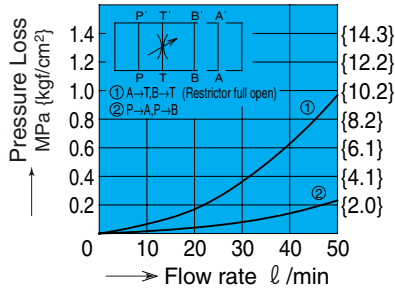

OCY-G01-P-20

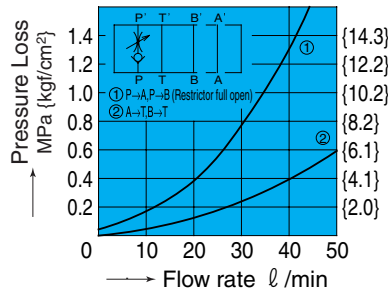

OCY-G01-W-Y-20
(OCY-G01-W-X-20)

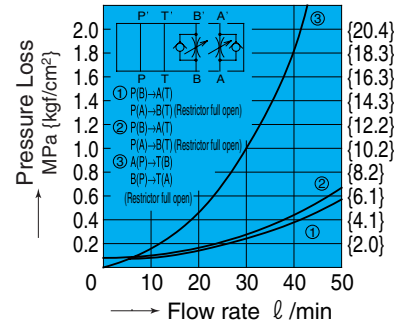

OCY-G03-P-J50

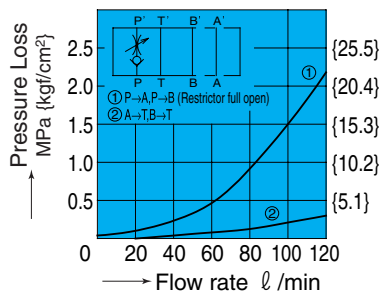

OCY-G03-W-Y-J51
(OCY-G03-W-X-J51)

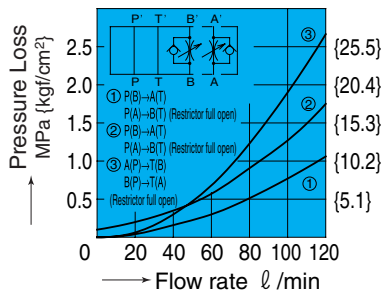

OYH-G04-P-10

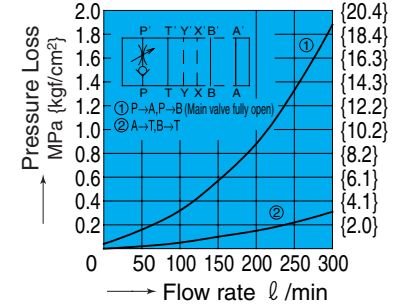

OYH-G04-W-Y-10
(OYH-G04-W-X-10)

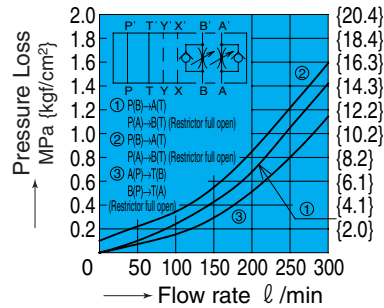

Stroke — Flow Rate Characteristics

OY-G01-T-20

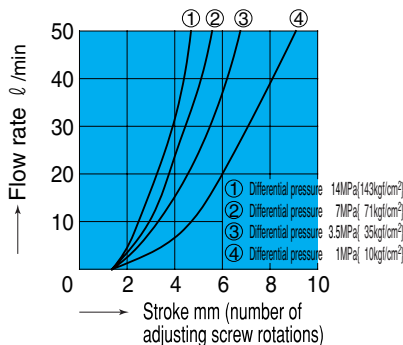

OCY-G01-P-20

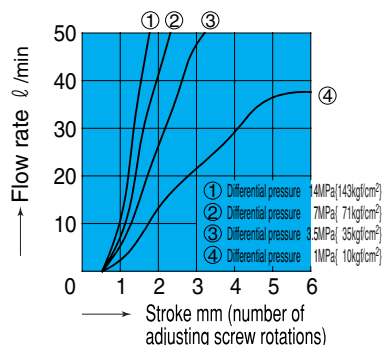

OCY-G01-*-*-20

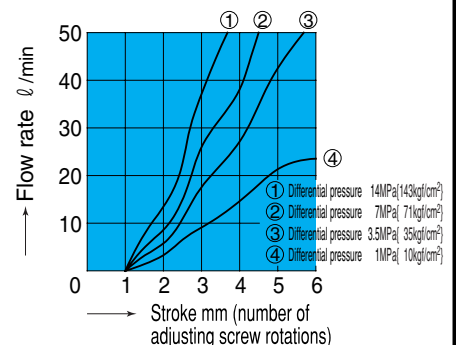

OCY-G03-P-(H)-J50

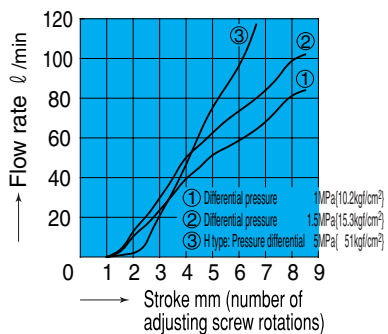

OCY-G03-W-(H)Y-J51

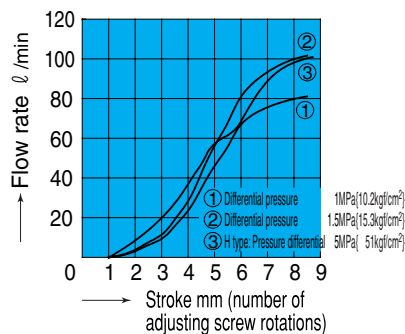

OYH-G04-P-10

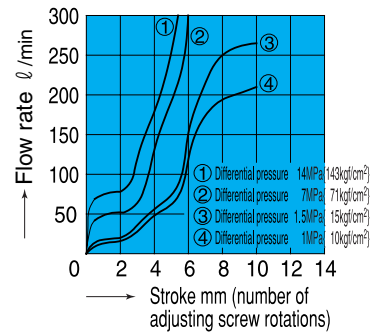

OYH-G04-W-Y-10

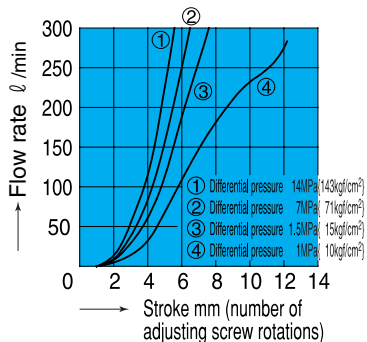

Cross-sectional Drawing

OY-G01-T-20

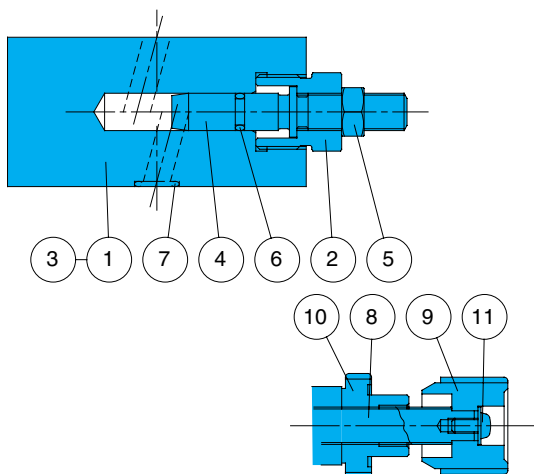

Part No.	Part Name
1	Body
2	Retainer
3	Plate
4	Screw
5	Nut
6	O-ring
7	O-ring
8	Screw
9	Knob
10	Nut
11	Screw

Seal Part List (Kit Model Number BFBS-01YT)

Part No.	Part Name	Part Number	Q'ty
6	O-ring	1B-P7	1
7	O-ring	1B-P9	4

Note) O-ring 1A/B-** refers to JIS B2401-1A/B.

OCY-G01-P-20

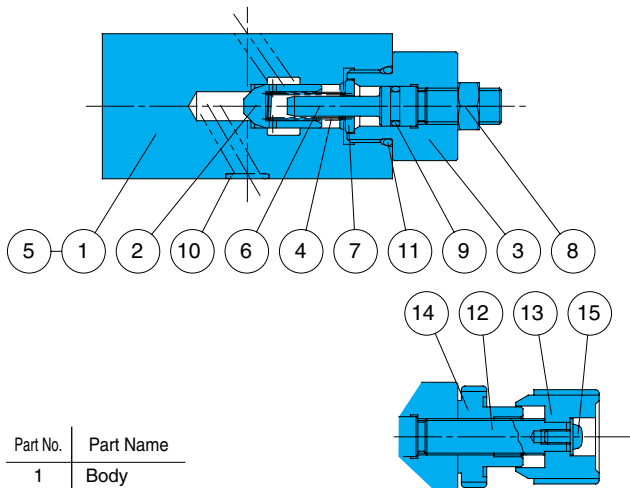

Part No.	Part Name
1	Body
2	Throttle
3	Retainer
4	Spring
5	Plate
6	Screw
7	Ring
8	Nut
9	O-ring
10	O-ring
11	O-ring
12	Screw
13	Knob
14	Nut
15	Screw

Seal Part List (Kit Model Number BFBS-01CYP)

Part No.	Part Name	Part Number	Q'ty
9	O-ring	1B-P8	1
10	O-ring	1B-P9	4
11	O-ring	1B-P18	1

Note) O-ring 1A/B-** refers to JIS B2401-1A/B.

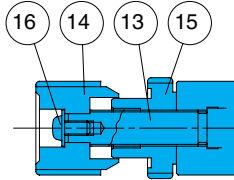
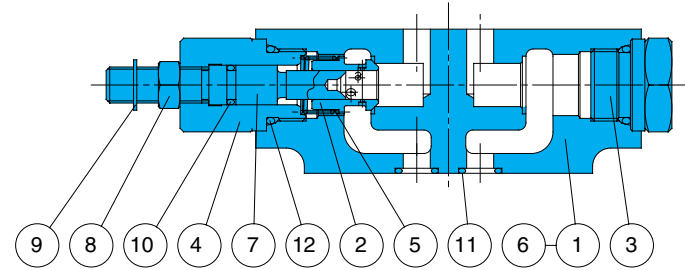

Seal Part List (Kit Model Number BFBS-01CY*)

Part No.	Part Name	Part Number	Q'ty		
			W	A	B
10	O-ring	1B-P8	2	1	1
11	O-ring	1B-P9	4	4	4
12	O-ring	1B-P18	2	2	2

Note) 1. O-ring 1A/B-** refers to JIS B2401-1A/B.
2. Specify W, A, or B for the asterisk (*) in the kit model number.

Part No.	Part Name
1	Body
2	Throttle
3	Bushing
4	Retainer
5	Spring
6	Plate
7	Screw
8	Nut
9	E-ring
10	O-ring
11	O-ring
12	O-ring
13	Screw
14	Knob
15	Nut
16	Screw

OCY-G03-P-J50

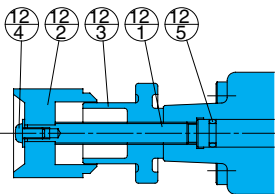
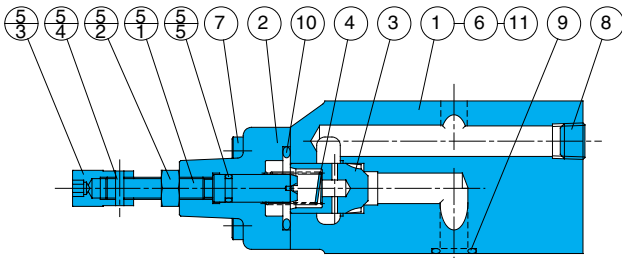

Seal Part List (Kit Model Number BFES-03CYP)

Part No.	Part Name	Part Number	Q'ty
			P
5(12) ^{-s}	O-ring	1B-P7	1
9	O-ring	AS568-014(Hs90)	5
10	O-ring	1B-P24	1

Note) O-ring 1A/B-** refers to JIS B2401-1A/B.

Part No.	Part Name
1	Body
2	Cover
3	Throttle
4	Spring
5	Screw kit
5 ₁	Screw
5 ₂	Nut
5 ₃	Nut
5 ₄	Pin
5 ₅	O-ring
6	Plate
7	Screw
8	Plug
9	O-ring
10	O-ring
11	Pin
12	Handle kit
12 ₁	Screw
12 ₂	Knob
12 ₃	Nut
12 ₄	Screw
12 ₅	O-ring

OCY-G03-A-Y-J51

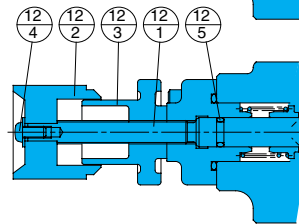
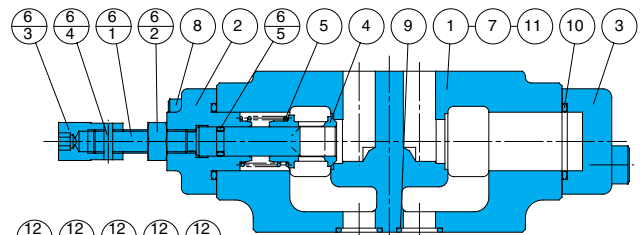

Seal Part List (Kit Model Number BFES-03CY*)

Part No.	Part Name	Part Number	Q'ty		
			W	A	B
6(12) ^{-s}	O-ring	1B-P7	2	1	1
9	O-ring	AS568-014(Hs90)	5	5	5
10	O-ring	1B-P22	2	2	2

Note) 1. O-ring 1A/B-** refers to JIS B2401-1A/B.
2. Specify W, A, or B for the asterisk (*) in the kit model number.

Part No.	Part Name
1	Body
2	Cover
3	Cover
4	Throttle
5	Spring
6	Screw kit
6 ₁	Screw
6 ₂	Nut
6 ₃	Nut
6 ₄	Pin
6 ₅	O-ring
7	Plate
8	Screw
9	O-ring
10	O-ring
11	Pin
12	Handle kit
12 ₁	Screw
12 ₂	Knob
12 ₃	Nut
12 ₄	Screw
12 ₅	O-ring

OYH-G04-P-10

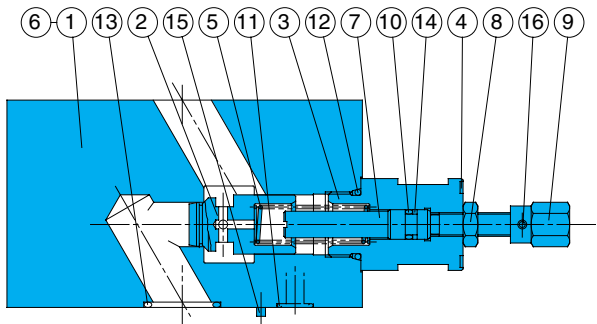

OYH-G04-A-Y-10

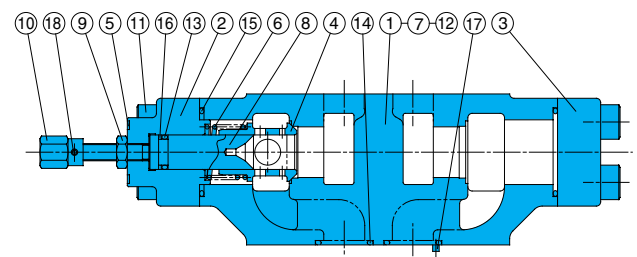

Seal Part List
(Kit Model Number BFKS-04CYP)

Part No.	Part Name	Part Number	Q'ty
			P
10	O-ring	1B-P7	1
11	O-ring	AS568-012(Hs90)	2
12	O-ring	1B-P20	1
13	O-ring	AS568-118(Hs90)	4
14	Backup ring	T2-P7	1

Note) 1. O-ring 1A/B-** refers to JIS B2401-1A/B.
2. Backup ring indicates JIS B 2407-T2-**.

Part No.	Part Name
1	Body
2	Throttle Retainer
3	Plate
4	Plate
5	Spring
6	Plate
7	Screw
8	Nut
9	Nut
10	O-ring
11	O-ring
12	O-ring
13	O-ring
14	Backup ring
15	Pin
16	Pin

Seal Part List
(Kit Model Number BFKS-04CY*)

Part No.	Part Name	Part Number	Q'ty		
			W	A	B
12	O-ring	AS568-012 (Hs90)	2	2	2
13	O-ring	1A-P12	2	1	1
14	O-ring	AS568-118 (Hs90)	4	4	4
15	O-ring	AS568-127 (Hs90)	2	2	2
16	Backup ring	T2-P12	2	1	1

Note) 1. O-ring 1A/B-** refers to JIS B2401-1A/B.
2. Backup ring indicates JIS B 2407-T2-**.
3. Specify W, A, or B for the asterisk (*) in the kit model number.

Part No.	Part Name
1	Body
2	Cover
3	Cover
4	Throttle Plate
5	Spring
6	Plate
7	Screw
8	Nut
9	Nut
10	O-ring
11	O-ring
12	O-ring
13	O-ring
14	O-ring
15	O-ring
16	Backup ring
17	Pin
18	Pin