

Check Modular Valve

50 to 300 ℓ /min
25,35MPa



Features

- ① This modular valve is a check valve that prevents reverse-flow.
- ② The 01, 03, 04 sizes include types that can also be used as suction and differential circuits.
- ③ Maximum Operating Pressure: 25, 35MPa {255, 357kgf/cm²}

Specifications

Model No.	Nominal Diameter (Size)	Maximum Working Pressure MPa{kgf/cm ² }	Maximum Flow Rate ℓ /min	Cracking pressure MPa{kgf/cm ² }	Weight kg	Gasket Surface Dimensions
OC-G01-P1-20 P2 P3	1/8	25{255}	50	0.04{0.4}	1.0	ISO 4401-03-02-0-94
				0.35{3.6}		
				0.50{5.1}		
OC-G01-T1-20 T2 T3				0.04{0.4}		
				0.35{3.6}		
	0.50{5.1}					
OC-G01-A1-21 A2 A3				0.04{0.4}	1.2	
				0.35{3.6}		
				0.50{5.1}		
OC-G01-AP1-20 AP2 AP3				0.04{0.4}	1.0	
				0.35{3.6}		
				0.50{5.1}		
OCV-G01-W-20				0.015{0.15}	1.0	
OC-G03-P1-J50 P2 P3	3/8	25{255}	100	0.04{0.4}	2.7	ISO 4401-05-04-0-94
				0.35{3.6}		
				0.50{5.1}		
OC-G03-T1-J50 T2 T3				0.04{0.4}		
				0.35{3.6}		
	0.50{5.1}					
OC-G03-A1-J50 A2 A3				0.04{0.4}	2.7	
				0.35{3.6}		
				0.50{5.1}		
OC-G03-AP1-J50 AP2 AP3				0.04{0.4}	2.7	
				0.35{3.6}		
				0.50{5.1}		
OCV-G03-W-J50				0.015{0.15}	3.5	
OCH-G04-P1-10 P2 P3	1/2	35{357}	300	0.04{0.4}	4.5	ISO 4401-07-06-0-94
				0.35{3.6}		
				0.50{5.1}		
OCH-G04-T1-10 T2 T3				0.04{0.4}		
				0.35{3.6}		
	0.50{5.1}					
OCH-G04-A1-10 A2 A3				0.04{0.4}	4.5	
				0.35{3.6}		
				0.50{5.1}		
OCH-G04-AP1-10 AP2 AP3				0.04{0.4}	4.5	
				0.35{3.6}		
				0.50{5.1}		
OVH-G04-W-10				0.01{0.1}	6.5	

● Handling

- ① Differential circuit can be easily configured at P → B by attaching OC-G**-A* above the OC-G**-AP* on the sub-plate. (See the figure to the right.)
- ② Note that a sub plate and installation bolts are not included. See pages D-90 through D-95 if these items are required.
- ③ 04 series modular valves do not have an L (DR₂) drain port, so they cannot be used in combination with pressure center type solenoid valves (D).

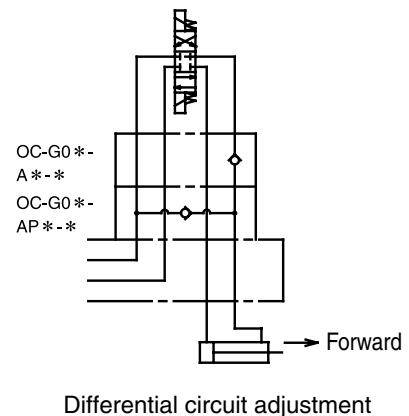

Understanding Model Numbers

01, 03 size

OC (OCV) - G 03 - P 1 - J50

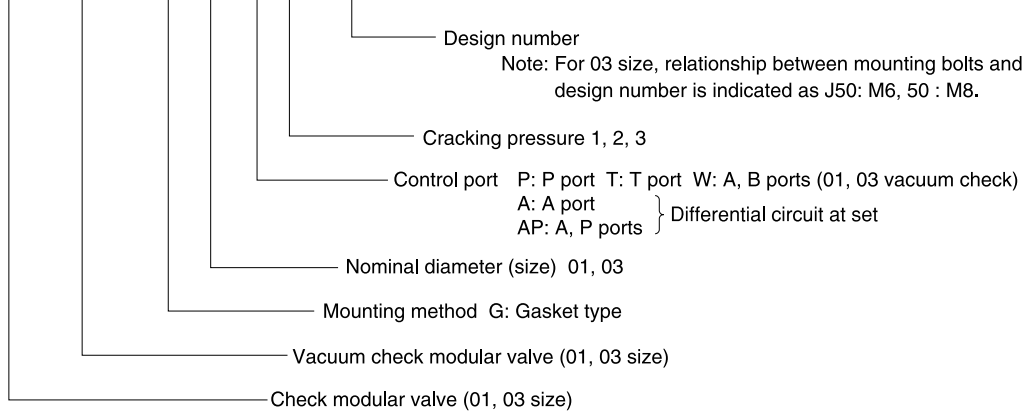

Understanding Model Numbers

04 size

OCH (OVH) - G 04 - P 1 - 10

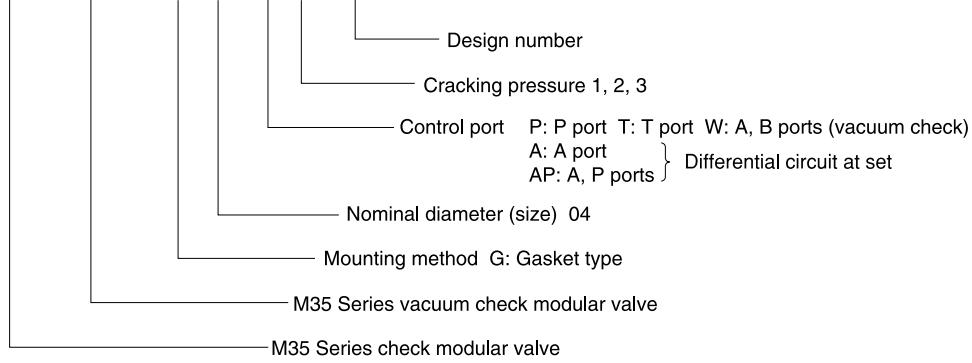

Installation Dimension Drawings

OC-G01-T*-20
P
AP

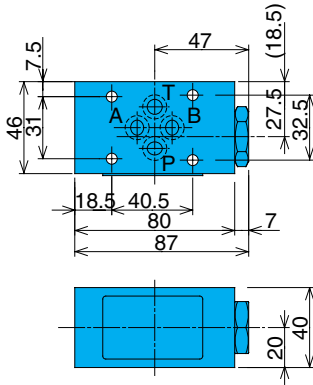

OC-G01-A*-21

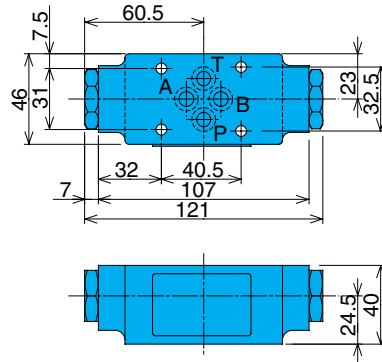

OCV-G01-W-20

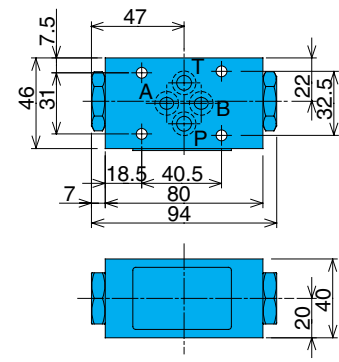

Note) Dimensions in the parentheses are for the OC-G01-T*-20.

OC-G03-^P_{AP}*-J50

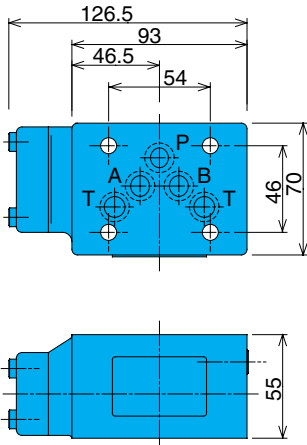

OC-G03-A*-J50

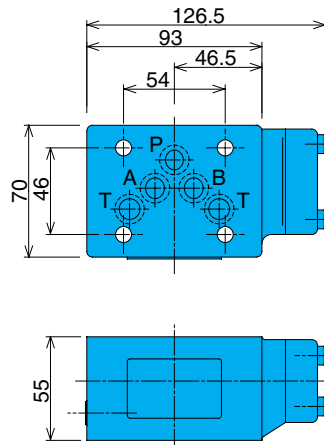

OC-G03-T*-J50

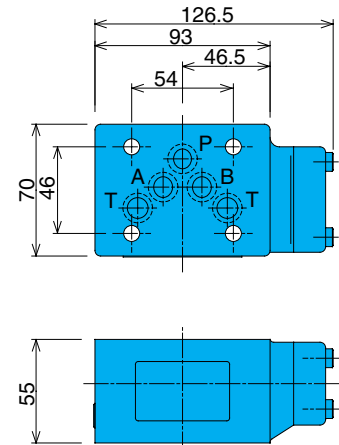

OCV-G03-W-J50

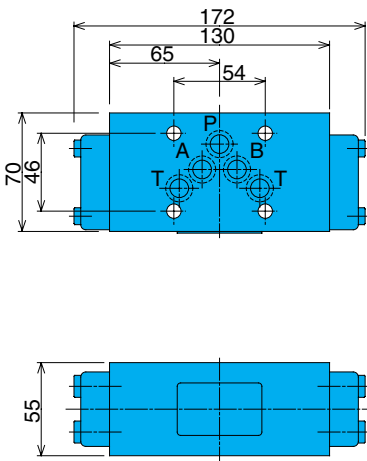

OCH-G04-A*-10
P
AP

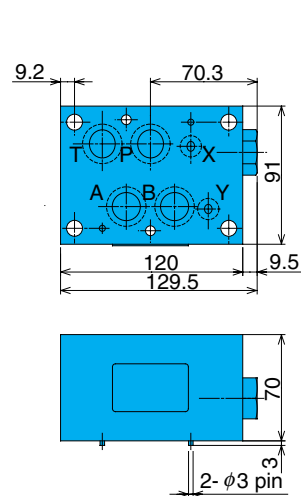

OCH-G04-T*-10

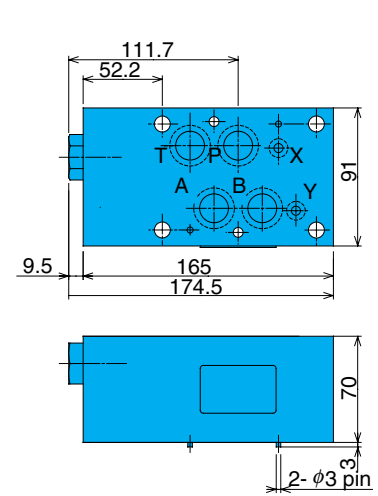

OVH-G04-W-10

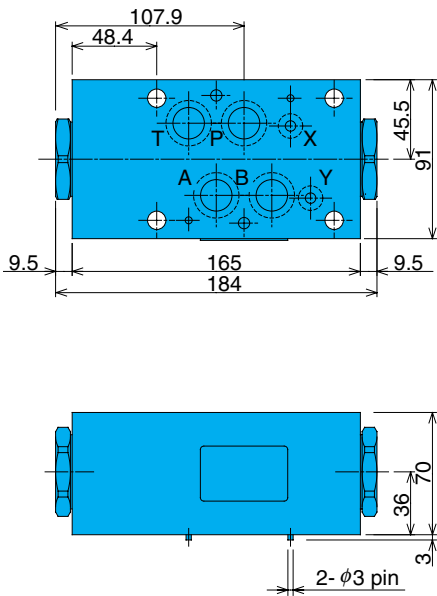

Performance Curves

Hydraulic Operating Fluid Viscosity 32mm²/s

Pressure Loss Characteristics

OC-G01-P*-20

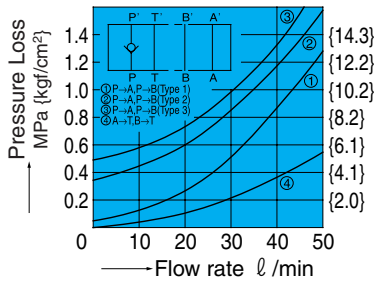

OCV-G01-W-20

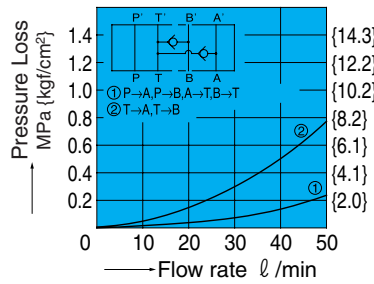

OC-G03-P*-J50

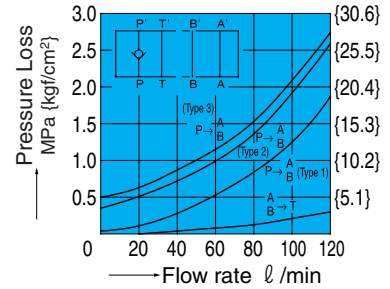

OC-G03-AP*-J50

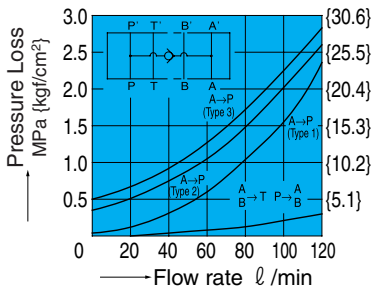

OC-G03-A*-J50

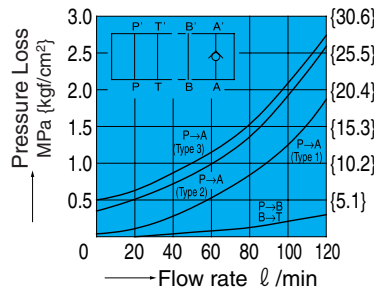

OC-G03-T*-J50

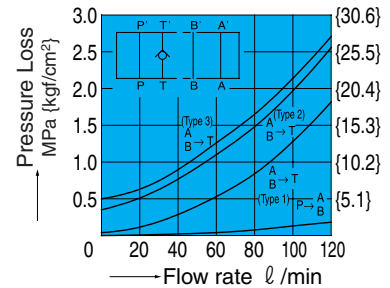

OCV-G03-W-J50

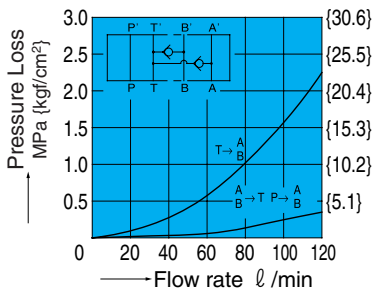

OCH-G04-P*-10

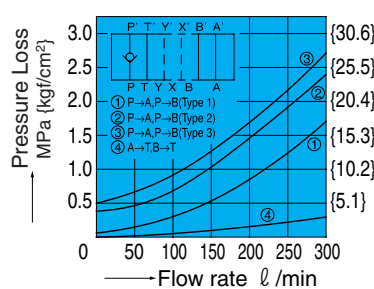

OCH-G04-T*-10

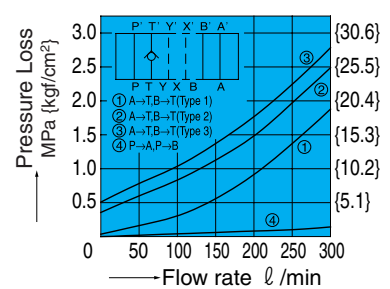

OCH-G04-A*-10

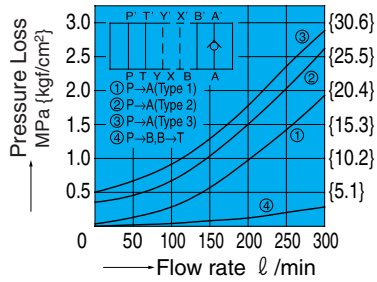

OCH-G04-AP*-10

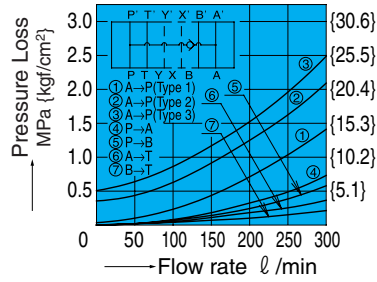

OVH-G04-W-10

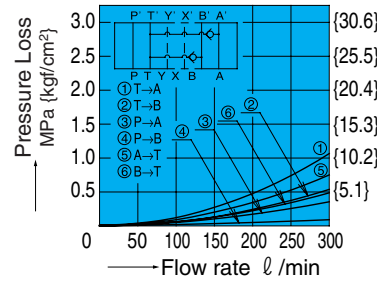

Cross-sectional Drawing

OC-G01-T*-20
AP

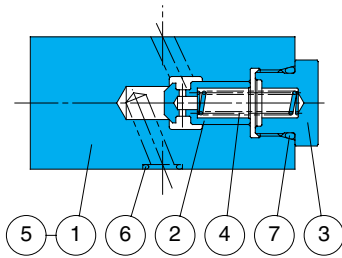

Part No.	Part Name
1	Body
2	Poppet
3	Spring seat
4	Spring
5	Plate
6	O-ring
7	O-ring

OC-G01-A*-21

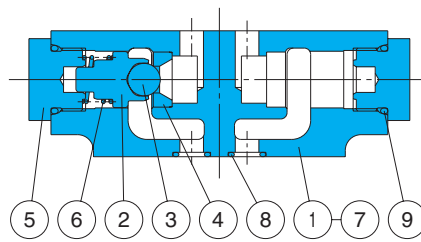

Part No.	Part Name
1	Body
2	Poppet
3	Ball
4	Seat
5	Spring seat
6	Spring
7	Plate
8	O-ring
9	O-ring

Seal Part List (Kit Model Number BRBS-01C*)

Part No.	Part Name	Part Number	Q'ty		
			P	T	AP
6	O-ring	1B-P9	4	4	4
7	O-ring	1B-P18	1	1	1

Note)
1. O-ring 1A/B-** refers to JIS B2401-1A/B.
2. Specify P, T, or AP for the asterisk (*) in the kit model number.

Seal Part List (Kit Model Number BDBS-01CA)

Part No.	Part Name	Part Number	Q'ty
			A
8	O-ring	1B-P9	4
9	O-ring	1B-P18	2

Note)
O-ring 1A/B-** refers to JIS B2401-1A/B.

OCV-G01-W-20

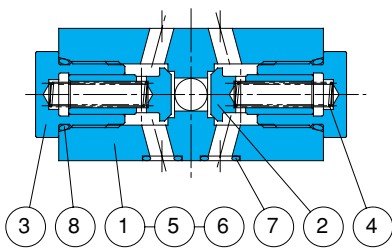

Part No.	Part Name
1	Body
2	Poppet
3	Guide
4	Spring
5	Plate
6	Plug
7	O-ring
8	O-ring

Seal Part List (Kit Model Number BDBS-01CVW)

Part No.	Part Name	Part Number	Q'ty
			W
7	O-ring	1B-P9	4
8	O-ring	1B-P18	2

Note)
1. O-ring 1A/B-** refers to JIS B2401-1A/B.

OC-G03-P*-J50

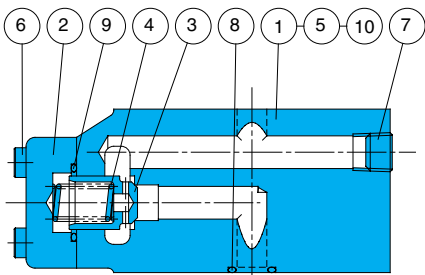

Part No.	Part Name
1	Body
2	Cover
3	Poppet
4	Spring
5	Plate
6	Screw
7	Plug
8	O-ring
9	O-ring
10	Pin

OC-G03-T*-J50

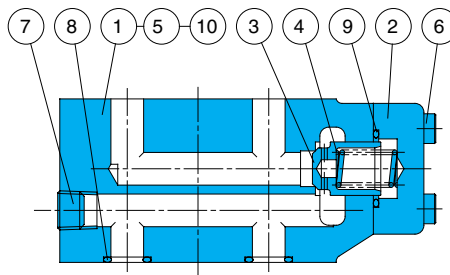

Part No.	Part Name
1	Body
2	Cover
3	Poppet
4	Spring
5	Plate
6	Screw
7	Plug
8	O-ring
9	O-ring
10	Pin

OC-G03-A*-J50

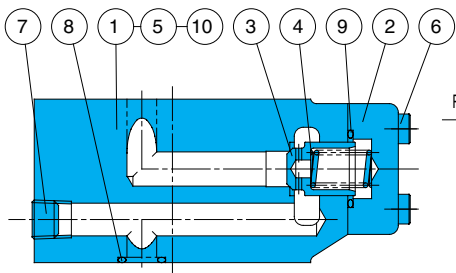

Part No.	Part Name
1	Body
2	Cover
3	Poppet
4	Spring
5	Plate
6	Screw
7	Plug
8	O-ring
9	O-ring
10	Pin

OC-G03-AP*-J50

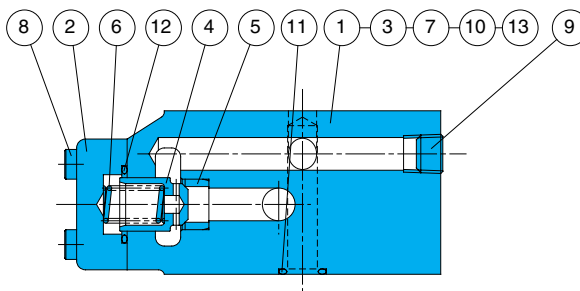

Part No.	Part Name
1	Body
2	Cover
3	Plug
4	Poppet
5	Seat
6	Spring
7	Plate
8	Screw
9	Plug
10	O-ring
11	O-ring
12	O-ring
13	Pin

Seal Part List (Kit Model Number BDES-03C*)

Part No.	Part Name	Part Number	Q'ty		
			P	T	A
8	O-ring	AS568-014(Hs90)	5	5	5
9	O-ring	1B-P22	1	1	1

Note)

- O-ring 1A/B-** refers to JIS B2401-1A/B.
- Specify P, T, or A for the asterisk (*) in the kit model number.

Seal Part List (Kit Model Number BDES-03CAP)

Part No.	Part Name	Part Number	Q'ty
			AP
10	O-ring	1B-P11	1
11	O-ring	AS568-014(Hs90)	5
12	O-ring	1B-P22	1

Note)

- O-ring 1A/B-** refers to JIS B2401-1A/B.

OCV-G03-W-J50

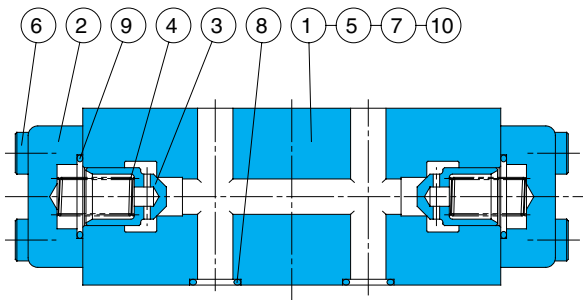

Seal Part List (Kit Model Number BDES-03CVW)

Part No.	Part Name	Part Number	Q'ty
			W
7	O-ring	1B-P10A	2
8	O-ring	AS568-014(Hs90)	5
9	O-ring	1B-P22	2

Part No.	Part Name	Part No.	Part Name	Part No.	Part Name
1	Body	5	Plate	9	O-ring
2	Cover	6	Screw	10	Pin
3	Poppet	7	O-ring		
4	Spring	8	O-ring		

OCH-G04-P*-10

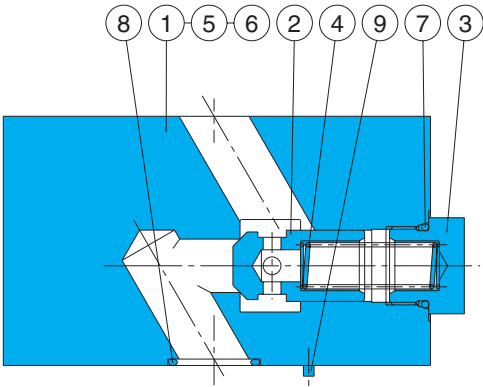

Part No.	Part Name
1	Body
2	Poppet
3	Spring seat
4	Spring
5	Plate
6	O-ring
7	O-ring
8	O-ring
9	Pin

OVH-G04-W-10

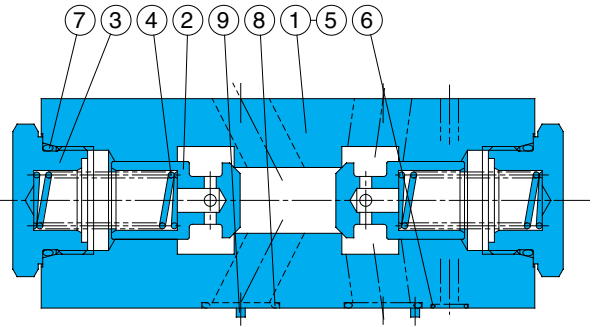

Part No.	Part Name
1	Body
2	Poppet
3	Spring seat
4	Spring
5	Plate
6	O-ring
7	O-ring
8	O-ring
9	Pin

Seal Part List (Kit Model Number BDKS-04C*)

Part No.	Part Name	Body	Q'ty			
			P	T	A	AP
6	O-ring	AS568-012(Hs90)	2	2	2	2
7	O-ring	1B-P20	1	1	1	1
8	O-ring	AS568-118(Hs90)	4	4	4	4

Seal Part List (Kit Model Number BDKS-04CVW)

Part No.	Part Name	Part Number	Q'ty
6	O-ring	AS568-012(Hs90)	2
7	O-ring	1B-P32	2
8	O-ring	AS568-118(Hs90)	4

Note) O-ring 1A/B-** refers to JIS B2401-1A/B.

- Note) 1.O-ring 1A/B-** refers to JIS B2401-1A/B.
 2.Specify P, T, A, or AP for the asterisk (*) in the kit model number.