

### Remote Control Relief Valve

2 to 15 ℓ /min  
21MPa

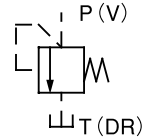

### Features

- ① Connecting a relief valve or reducing valve to the vent port of a balanced piston type pressure control valve provides simple remote control of pressure.
- ② RCD type can also be used as a direct type relief valve.

### Specifications

Model No.		Nominal Diameter (Size)	Maximum Working Pressure MPa(kgf/cm <sup>2</sup> )	Maximum Flow Rate ℓ /min	Pressure adjustment range MPa(kgf/cm <sup>2</sup> )	Weight kg
Screw Mounting	Gasket mounting					
RCD-T02-1-11 3-11	—	1/4	21{214} P, V ports	15	0.8 to 7{ 8.2 to 71.4 } 3.5 to 21{35.7 to 214 }	2.1
RC-T02-1-12 3-12	RC-G02-1-21 3-21					

Note) The pressure adjustment range indicates cracking pressure.

### Understanding Model Numbers

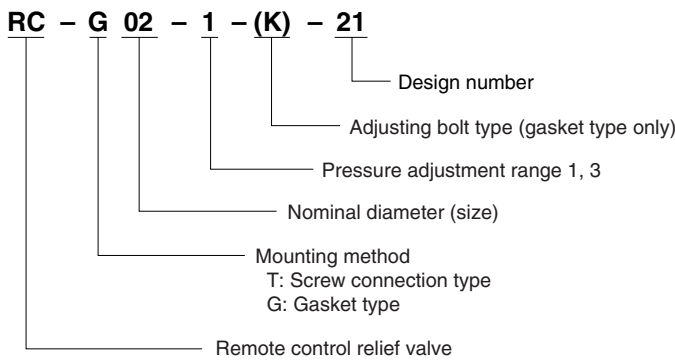

#### ● Handling

- 1 To adjust pressure, loosen the lock nut and then rotate the handle clockwise (rightward) to increase pressure or counterclockwise (leftward) to decrease it.
- 2 Make sure that drain port back pressure is no greater than 0.2MPa {2.0kgf/cm<sup>2</sup>}.
- 3 When configuring pipes for the pressure control valve and remote control valve, use of thick iron pipe with an inside diameter of no more than 4mm and a connection length of no more than three meters is recommended. Pipe capacity can be a source of vibration.
- 4 When an adjustment bolt type is required for the pressure adjustment block, insert K for the type specification. See the dimension drawings, RC-G02 only.
- 5 Use the following to specify a sub plate.

### Installation Dimension Drawings

RCD-T02-\* -11 (Screw Mounting)

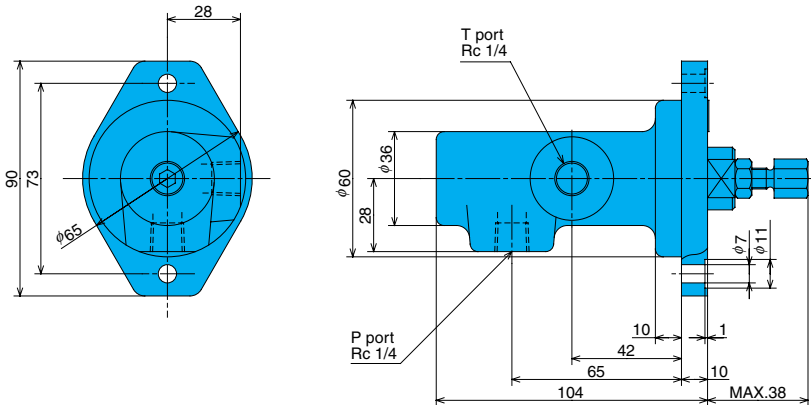

Model No.	Weight kg
MRC-02-20	1.0

- 6 The following are the bundled mounting bolts.

Model No.	Bolt Dimensions	Q'ty	Tightening Torque N·m(kgf·cm)
RC-G02-* -21	M8 × 25 ℓ	4	20 to 25 {205 to 255}

Note) For mounting bolts, use 12T or equivalent.

RC-T02-\*-12 (Screw Mounting)

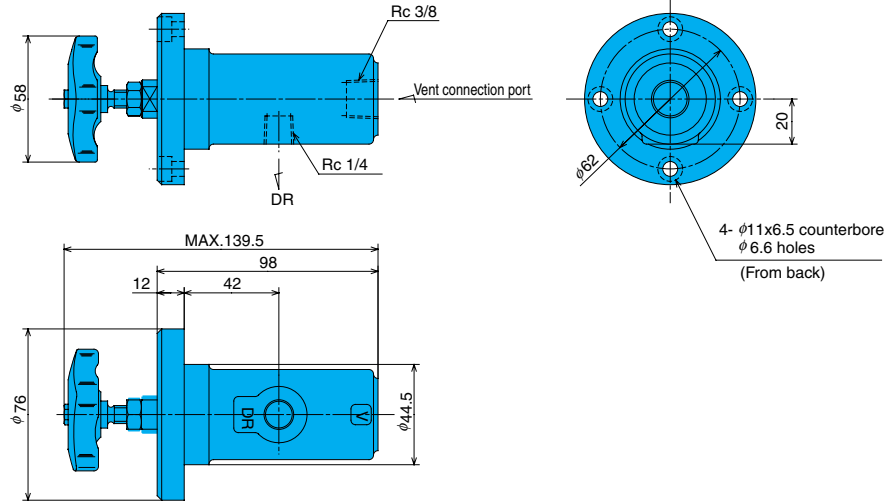

RC-G02-\*-21 (Gasket Mounting)

Sub Plate MRC-02-20

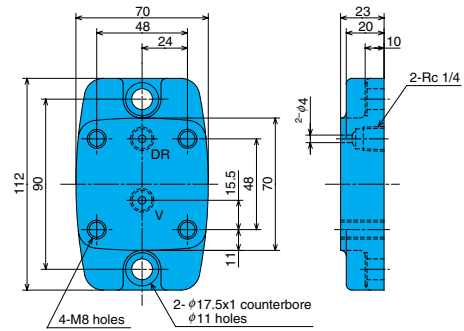
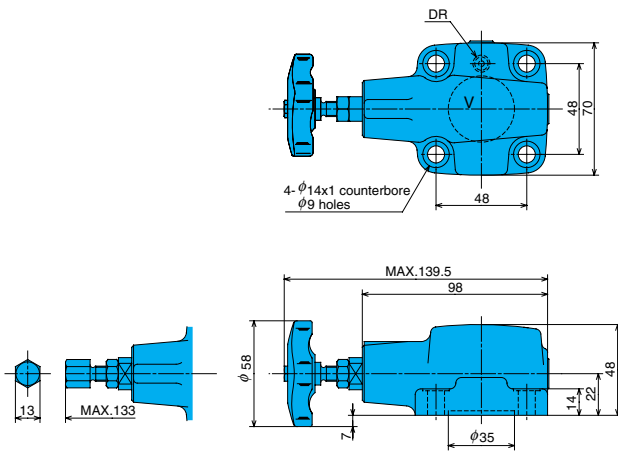

Cross-sectional Drawing

RCD-T02-\*-11

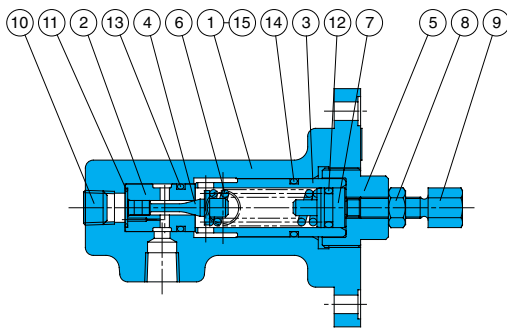

Part No.	Part Name	Part No.	Part Name
1	Body	12	O-ring
2	Sleeve	13	O-ring
3	Sleeve	14	O-ring
4	Poppet	15	Nameplate
5	Retainer		
6	Spring		
7	Guide		
8	Nut		
9	Screw		
10	Plug		
11	O-ring		

Seal Part List (Kit Model Number RCS-T02CD)

Part No.	Part Name	Part Number	Q'ty
11	O-ring	S12.5(NOK)	1
12	O-ring	1A-P11	1
13	O-ring	1B-P14	1
14	O-ring	1B-P18	1

Note) O-ring 1A/B-\*\* refers to JIS B2401 1A/B.

RC-G02-\*- (K)-21

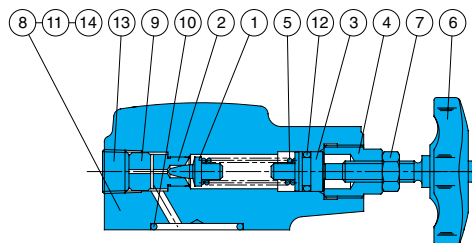

Seal Part List (Kit Model Number RCBS-G02)

Part No.	Part Name	Part Number	Q'ty
10	O-ring	1B-G30	1
11	O-ring	1B-P6	1
12	O-ring	1A-P11	1

Note) O-ring 1A/B-\*\* refers to JIS B2401 1A/B.

Part No.	Part Name
1	Poppet
2	Seat
3	Plunger
4	Retainer
5	Spring
6	Handle
7	Nut
8	Cover
9	Collar
10	O-ring
11	O-ring
12	O-ring
13	Plug
14	Plate