



High-speed Response Proportional Control Valve Amplifier EHA Series

Features

- Coil current feedback and spool position feedback amplification for stable, high-speed spool positioning.
- Built in check connector ICS simplifies maintenance.
- A single printed circuit board allows separation of connectors and the terminal box.
- Built-in differential transformer disconnect detection circuit drops coil current to 0mA when disconnection occurs.
- Servo ready and servo ON interfaces.
- Power supply and current control switching system for improved efficiency.

Specifications

Power Supply Voltage	24V DC (22V DC to 28V DC) Lip Noise: 150mVp-p max.
Power Supply Capacity	At least 2.1A (COSEL R50A-24 equivalent switching regulator)
Ambient Temperature	0 to 50°C
Ambient Humidity	35 to 85% RH (non-condensation)
Input Signal Voltage	0 to ±5V DC or 0 to ±10V DC
Input Impedance	50kΩ
Power Consumption	2.1A maximum consumption current at 24V
Weight	0.9kg
External Supply Voltage	+5V : (10mA maximum supply possible) -5V : (10mA maximum supply possible)
Drive Coil	2.5Ω; max. 2.7A or 5Ω; max. 2.4A
Spool Displacement Measurement	Differential transformer (LVDT)
Servo ON	Application of 24V DC during valve operation
Ready	During normal valve operation: ON
Spool displacement monitor	0 to ±5V

Understanding Model Numbers

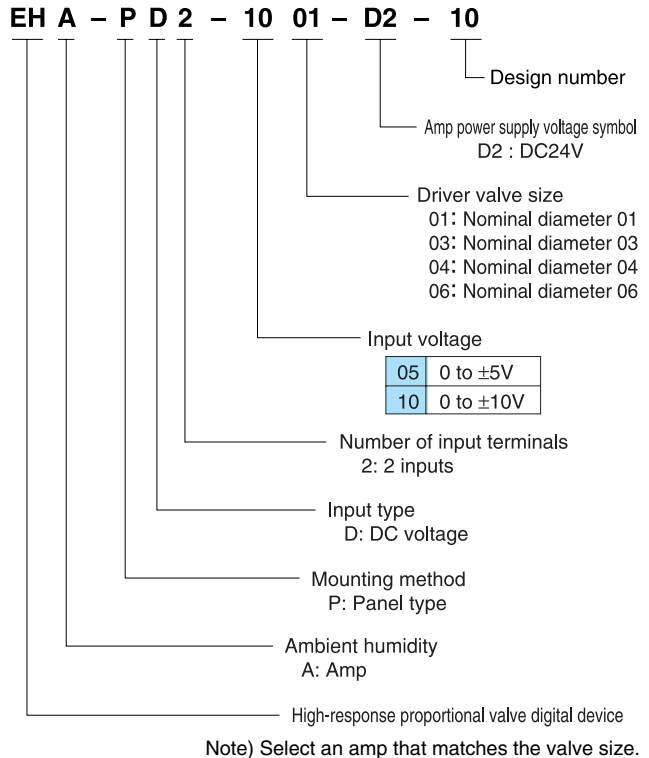

Installation Dimension Drawings

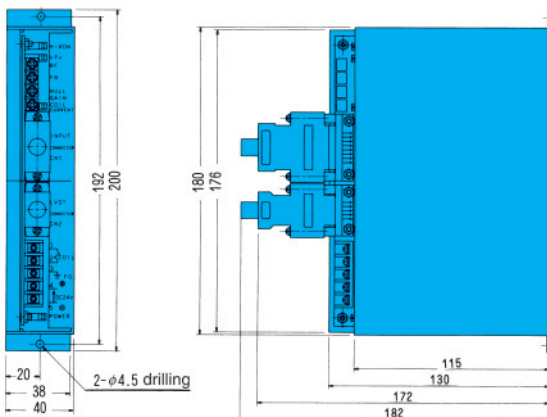

Block Diagram

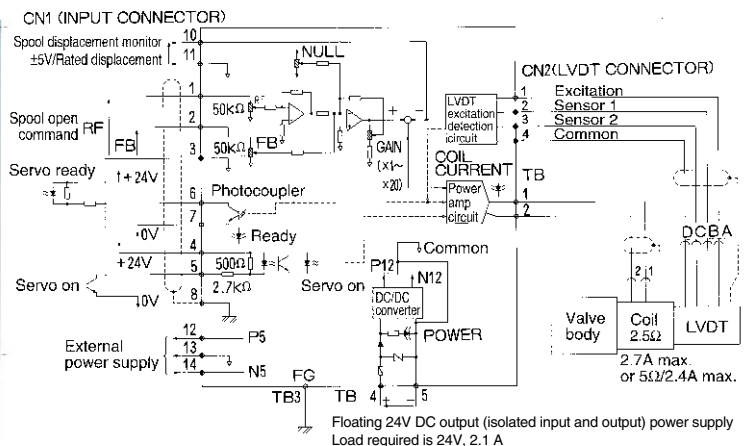

Note)
Since G03, G04, and G05 are pilot operation types, there is an LVDT on the main spool, but connection is identical.

(1) Example Application in ESH-G01 Positioning Circuit

This is an ESH-G01 positioning circuit using a sequencer. Proportional control is performed by the positioning unit, while integral compensation is performed by the counter unit and D/A unit. The result is high-precision positioning.

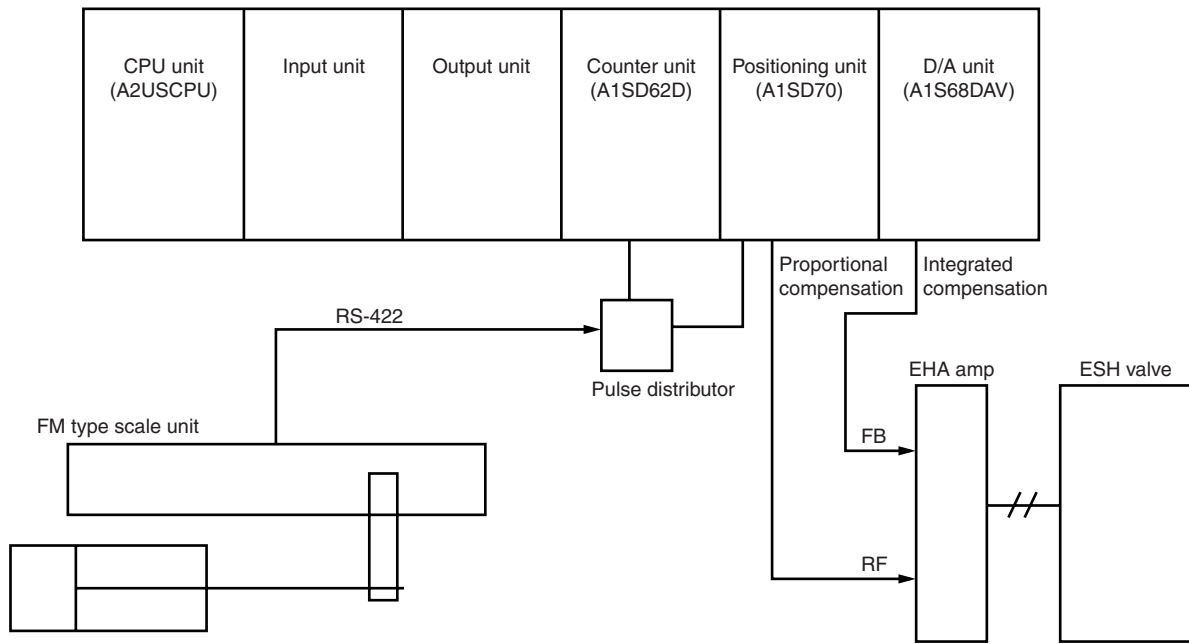

(2) Example Application in ESH-G03, G04, G06 Molding Machine Mold Clamping Circuit

This hydraulic circuit is a basic application example. The actual application hydraulic circuit would require modification to match the machinery and to provide the necessary functions. Cut off flow to the cylinder with the safety door valve and interlock solenoid valve, in accordance with the logic valve.

