



ガスケット形ストップバルブ

HG-4350

HGD-4350

呼び径 10^A、20^A、32^A、50^A、80^A

標準仕様

最高使用圧力	35MPa
漏れ検査圧力	52.5MPa
耐圧検査圧力	52.5MPa

注)バルブ取付用ボルト、Oリングは付属致します。

特長

完全なバランス機構で、ハンドル操作が容易で35MPaの高圧ラインに最適です。



JIS油圧図記号

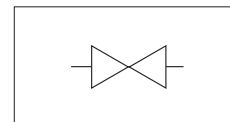

寸法図

HG-4350-10、20-23

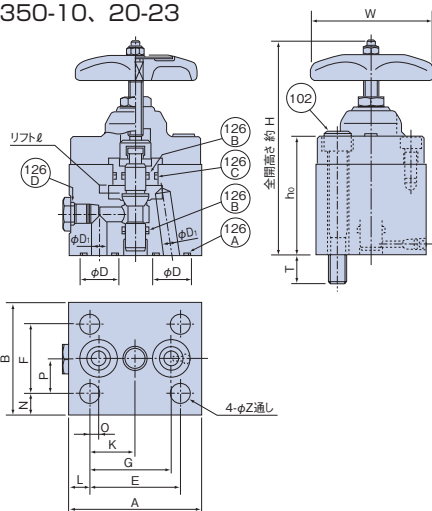

HGD-4350-32、50-23

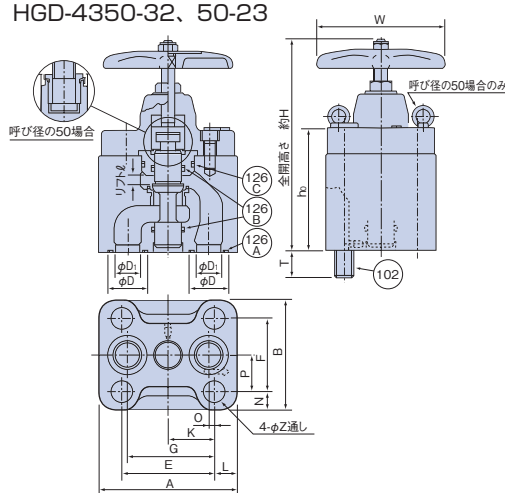

HGD-4350-80-23

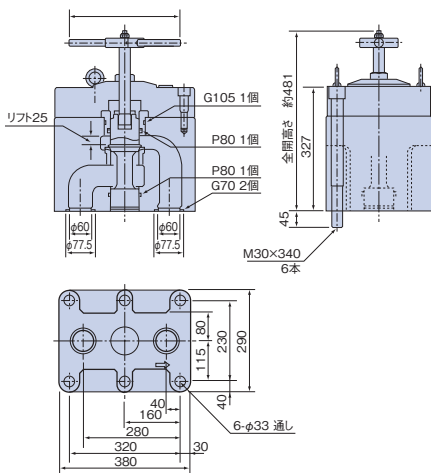

寸法表

モデルナンバ	取付寸法										102ボルト		D ₁	D	T	h ₀	W	H	リフト ℓ	Oリング呼び番号(JIS B 2401)				Z	質量 (kg)
	A	B	E	F	G	K	L	N	P	Q	呼び寸法	数								126A	126B	126C	126D		
HG-4350-10-23	87	72	59	44	53	29.5	14	14	22	6	M12×85	4	10	24.5	18	76	80	143.5	5	P18	P14	G25	P11	13.5	3.8
HG-4350-20-23	110	95	76	61	70	38	17	17	30.5	6	M16×105	4	16	32.5	23	95	100	178	7	G25	P20	G35	P18	17.5	8.0
HGD-4350-32-23	150	120	100	80	93.5	50	25	20	40	6.5	M20×145	4	26	42.5	29	130	140	235	10	G35	P30	G50		21.5	15.5
HGD-4350-50-23	240	200	170	130	158	85	35	35	65	12	M30×240	4	40	57.5	45	220	200	345	15	G50	P50	G75		33	59.0

■ 圧力降下特性 (粘度32mm²/s)

HG-4350-10-23

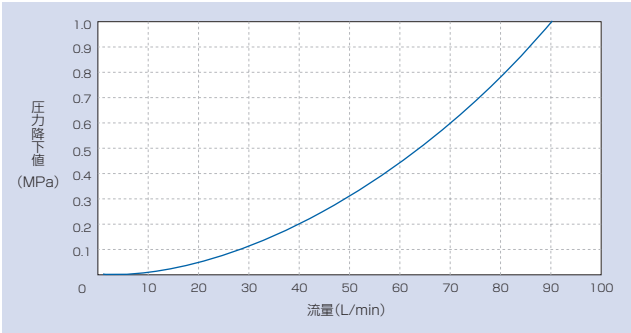

HGD-4350-50-23

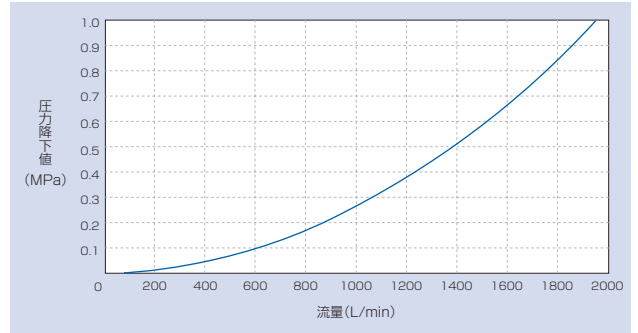

HG-4350-20-23

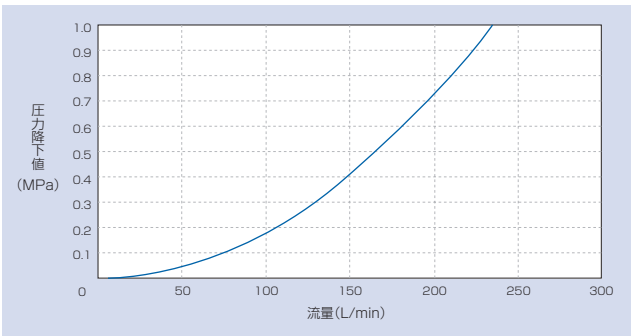

HGD-4350-80-23

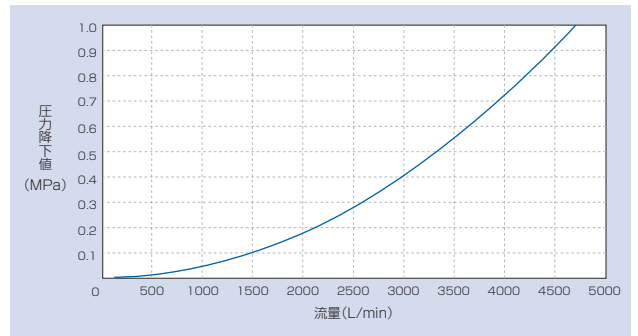

HGD-4350-32-23

